

KEY FEATURES

- High power handling (250 w AES)
- Low harmonic distortion
- Controlled dispersion up to 3 kHz
- 2" edgewound aluminium voice coil with polyimide fiber glass former
- Designed for high quality mid-frequency reproduction



GENERAL DESCRIPTION

This low-mid frequency transducer offers three main points of interest: a good sensitivity (98 dB), a controlled dispersion up to 3 kHz and a low harmonic distortion. These characteristics make it suitable for high quality sound reinforcement systems, especially for live applications. Furthermore, it is mounted with a cast aluminium basket that reduces mechanical vibrations and increases thermal dissipation. This fact, added to the use of a high quality 2" voice-coil, increases considerably the power handling reaching 250 w AES.

FREQUENCY RESPONSE AND DISTORTION CURVES

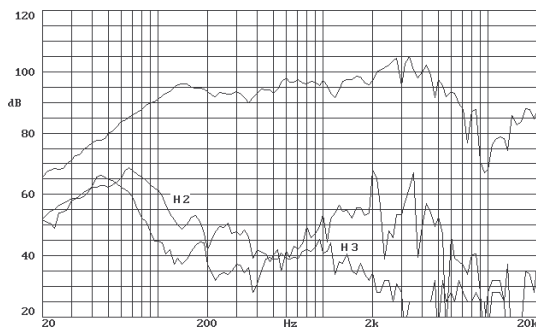

Note: on axis frequency response measured with loudspeaker standing on infinite baffle in anechoic chamber, 1w @ 1m.

FREE AIR IMPEDANCE CURVE

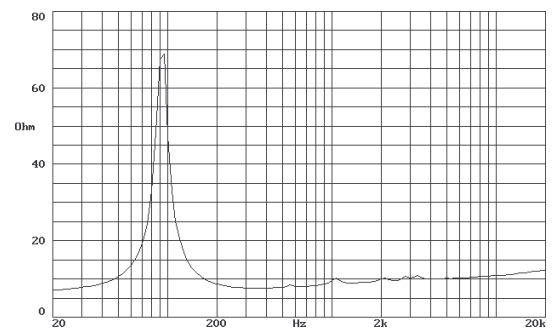

FREQUENCY RESPONSE OUT OF AXIS

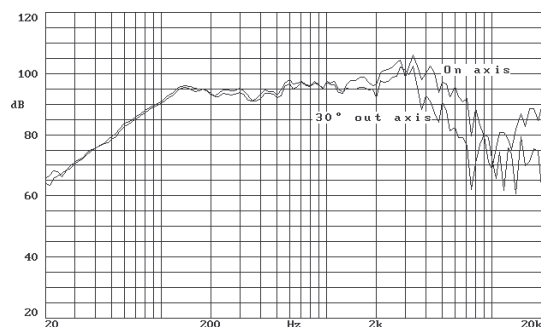

POWER COMPRESSION LOSSES

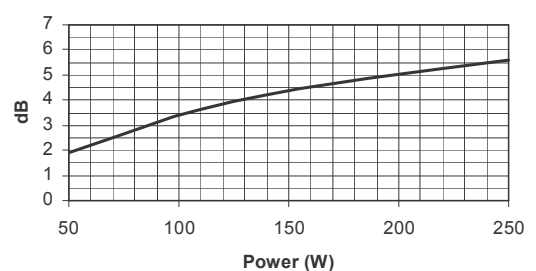

Note: These losses are calculated from a five minutes AES power test applying band limited pink noise (120-3500 Hz). The loudspeaker is free-air standing.

TECHNICAL SPECIFICATIONS

Nominal diameter	200 mm. 8 in.
Rated impedance	8 ohms.
Minimum impedance	6.9 ohms.
Power capacity *	250 w AES
Program power	500 w
Sensitivity	98 dB 2.83v @ 1m @ 2π
Frequency range	150 - 7000 Hz
Voice coil diameter	51.7 mm. 2 in.
Magnetic assembly weight	2.8 kg. 6.17 lb.
BL factor	9.8 N / A
Moving mass	0.017 kg.
Voice coil length	9 mm.
Air gap height	7 mm.

DIMENSION DRAWINGS

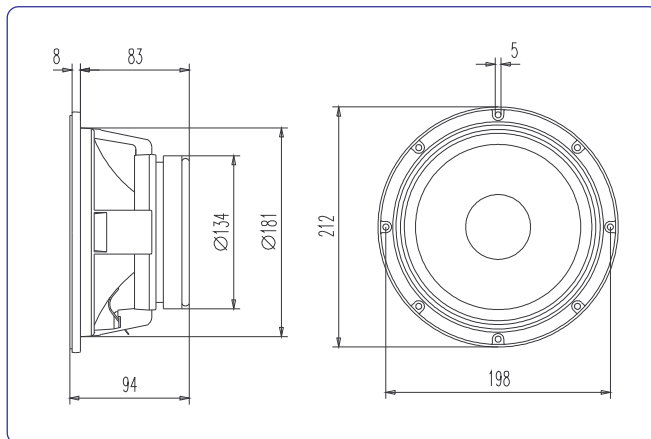

MOUNTING INFORMATION

Overall diameter	212 mm. 8.35 in.
Bolt circle diameter	198 mm. 7.8 in.
Baffle cutout diameter:	
- Front mount	181 mm. 7.12 in.
- Rear mount	183 mm. 7.2 in.
Depth	94 mm. 3.7 in.
Volume displaced by driver	1.5 l 0.056 ft. ³
Net weight	3.1 kg. 6.83 lb.
Shipping weight	3.25 kg. 7.15 lb.

MATERIALS

- **Voice coil:** edgewound aluminium wire with high temperature bonding strength. Polyimide fiber glass former able to withstand high temperatures.
- **Cone:** light and stiff paper cone to provide good mid-frequency response.
- **Surround:** plasticized cloth.
- **Spider:** cotton spider.
- **Metal parts:** effective protection against corrosion.
- **Basket:** specially designed die cast aluminium basket to avoid disturbing resonances.
- **Magnet:** high Curie temperature ferrite.

THIELE-SMALL PARAMETERS **

Resonant frequency, fs	90 Hz
D.C. Voice coil resistance, Re	6 ohms.
Mechanical Quality Factor, Qms	8.5
Electrical Quality Factor, Qes	0.6
Total Quality Factor, Qts	0.56
Equivalent Air Volume to Cms, Vas	13 l
Mechanical Compliance, Cms	186 μm / N
Mechanical Resistance, Rms	1.2 kg / s
Efficiency, ηo (%)	1.5
Effective Surface Area, Sd (m ²)	0.0220 m ²
Maximum Displacement, Xmax	1 mm.
Displacement Volume, Vd	22 cm. ³
Voice Coil Inductance, Le @ 1 kHz	0.2 mH

Notes:

*The power capacity is determined according to AES2-1984 (r2003) standard. Program power is defined as the transducer's ability to handle normal music program material.

**T-S parameters are measured after an exercise period using a preconditioning power test. The measurements are carried out with a velocity-current laser transducer and will reflect the long term parameters (once the loudspeaker has been working for a short period of time).



acústica beyma, s.a.