

USB12

MINIATURIZED USB CONDENSER MICROPHONE

OVERVIEW

The USB12 is the perfect desktop microphone for teleconferencing, podcasting and remote communication. This condenser microphone connects directly into a computer's USB port to naturally capture and reproduce vocals and instruments in stunning detail. Vocal clarity, excellent transient response, and ease of operation are the hallmarks of this unique microphone solution.

The USB12 is characterized with a uniformly controlled cardioid polar pattern and provides excellent isolation and control, which greatly reduces excess room sound. With a smooth and accurate response over a frequency range of 50 Hz - 16 kHz, the USB12 sits on top of a stable desktop base and can be easily adjusted to any position, thanks to the flexible gooseneck design.

This high definition condenser microphone features a membrane button with three options: "on-off", "push to talk" or "push to mute" along with a blue LED to signal activity. The USB12 also features a 3.5 mm headphone/monitor output for real time monitoring and a bass roll-off filter to control unwanted low frequency signals.

OPERATION AND MAINTENANCE

The USB12 is a condenser microphone designed to work with a USB port on any computer. The computer must be equipped with USB 2.0 or higher.

Plugging in the microphone — With the supplied cable, plug one end of the cable into the microphone and the other into the USB port on your computer. You will get a message to the effect of "Found New Hardware" and the drivers will load as "Audix USB12".

Depending on the type of computer you have and software, you will want to change the default setting of your audio microphone to the USB12 (Audix USB12). For more details visit our website www.audixusa.com.

Headphone output — By using the headphone output, you can monitor yourself in real time, without latency. You also have the option to use the headphone output for powered speakers.

Changing Capsules — The capsule on the USB12 is threaded and interchangeable with two other capsules - omni directional and hypercardioid. Capsules may be ordered separately from any authorized Audix dealer.

Switches on underside of the base — On-Off: This means that when you push the membrane switch on the front of the mic, it will turn the mic on and remain in that position until you push it again to turn it off. The blue LED will remain on, so you know it is active.

Push to talk: This means that the mic is only on when you push and hold the membrane switch. The LED will stay on only while holding the button down. Otherwise it is muted. This is useful if you are using the microphone where you are mostly listening or there is loud background noise.

Push to mute: This means that the mic is always on, unless you press the membrane switch. When the LED is lit, the mic is muted. This feature acts much like a "cough" button in a studio or the mute function on a smart phone.

Flat-Roll Off : This switch allows the microphone to have full frequency response (flat —) or with bass roll off (—), which eliminates or limits low frequency noise or vibration.



FEATURES

- Plug and play: connects directly into computer via USB port
- Mac and PC compatible
- Flexible gooseneck design
- 3.5 mm headphone output for real time monitoring
- Toggle Switch: On-Off, Push to Talk, Push to Mute
- Bass roll-off filter
- Studio quality sound
- 16-bit sample resolution
- Supports 44.1 k and 48 k sample rates

SUPPLIED ACCESSORIES

- CBLUSB6 - 6' USB cable
- WS1218 - External windscreen

OPTIONAL REPLACEMENT CAPSULES

- CPSADXHC - Hypercardioid
- CPSADXO - Omni-directional

AUDIX®

USB12 Spec Sheet v2.0

ARCHITECT AND ENGINEER SPECIFICATIONS

The microphone shall be of the pre-polarized condenser type with a modular threaded capsule available in cardioid, hypercardioid and omni-directional patterns. The microphone shall operate on 5 V via USB connection. The microphone shall consist of brass parts, aluminum tubing, and coiled steel gooseneck.

DIMENSIONS (mm)

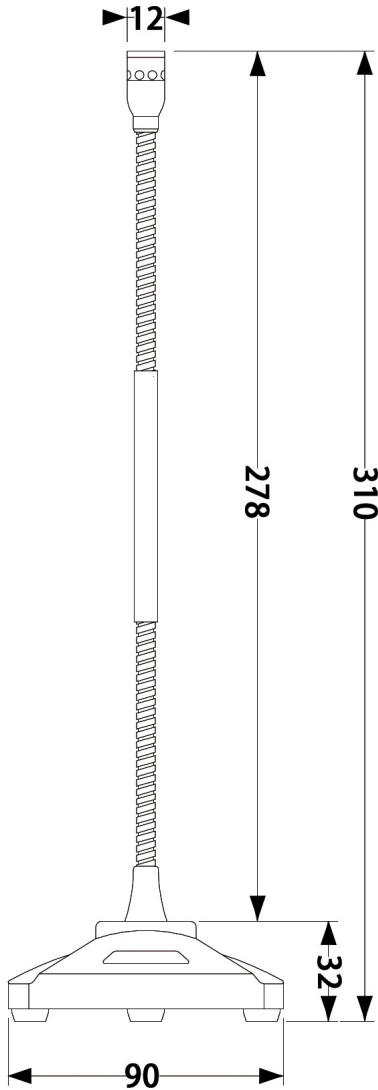

SPECIFICATIONS

Transducer Type	Pre-Polarized Condenser
Frequency Response	50 Hz - 16 kHz
Polar Pattern	Cardioid
Output Impedance	1000 ohms
Signal to Noise Ratio	64 dB, 1 k @ 1 Pa
Maximum SPL	115 dB
Dynamic Range	85 dB
Operating Voltage	5 V via USB connection
Switch Type	Membrane
Roll-off Filter	@ 150 Hz
Sampling Rate	16 bit, 44.1 k / 48 k for both playback and recording
Toggle Switch Function	On-Off, Push to Talk or Push to Mute
Materials / Finish	Brass / Metal Base / Matte black
Weight	567 g / 20 oz
Length	310 mm / 12.2 in

FREQUENCY RESPONSE

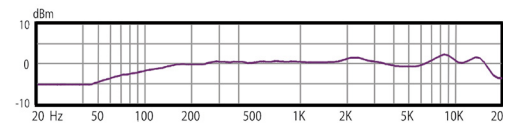

POLAR PATTERNS

