

Thump 12 • Thump 15

1000W Powered Loudspeakers

OWNER'S MANUAL



Important Safety Instructions

1. Read these instructions.
2. Keep these instructions.
3. Heed all warnings.
4. Follow all instructions.
5. Do not use this apparatus near water.
6. Clean only with a dry cloth.
7. Do not block any ventilation openings. Install in accordance with the manufacturer's instructions.
8. Do not install near any heat sources such as radiators, heat registers, stoves, or other apparatus (including amplifiers) that produce heat.
9. Do not defeat the safety purpose of the polarized or grounding-type plug. A polarized plug has two blades with one wider than the other. A grounding-type plug has two blades and a third grounding prong. The wide blade or the third prong are provided for your safety. If the provided plug does not fit into your outlet, consult an electrician for replacement of the obsolete outlet.
10. Protect the power cord from being walked on or pinched particularly at plugs, convenience receptacles, and the point where they exit from the apparatus.
11. Only use attachments/accessories specified by the manufacturer.
12. Use only with a cart, stand, tripod, bracket, or table specified by the manufacturer, or sold with the apparatus. When a cart is used, use caution when moving the cart/apparatus combination to avoid injury from tip-over.
13. Unplug this apparatus during lightning storms or when unused for long periods of time.
14. Refer all servicing to qualified service personnel. Servicing is required when the apparatus has been damaged in any way, such as power-supply cord or plug is damaged, liquid has been spilled or objects have fallen into the apparatus, the apparatus has been exposed to rain or moisture, does not operate normally, or has been dropped.
15. This apparatus shall not be exposed to dripping or splashing, and no object filled with liquids, such as vases or beer glasses, shall be placed on the apparatus.
16. Do not overload wall outlets and extension cords as this can result in a risk of fire or electric shock.
17. This apparatus has been designed with Class-I construction and must be connected to a mains socket outlet with a protective earthing connection (the third grounding prong).
18. This apparatus has been equipped with a rocker-style AC mains power switch. This switch is located on the rear panel and should remain readily accessible to the user.
19. The MAINS plug or an appliance coupler is used as the disconnect device, so the disconnect device shall remain readily operable.



20. NOTE: This equipment has been tested and found to comply with the limits for a Class B digital device, pursuant to part 15 of the FCC Rules. These limits are designed to provide reasonable protection against harmful interference in a residential installation. This equipment generates, uses, and can radiate radio frequency energy and, if not installed and used in accordance with the instructions, may cause harmful interference to radio communications. However, there is no guarantee that interference will not occur in a particular installation. If this equipment does cause harmful interference to radio or television reception, which can be determined by turning the equipment off and on, the user is encouraged to try to correct the interference by one or more of the following measures:

- Reorient or relocate the receiving antenna.
- Increase the separation between the equipment and the receiver.
- Connect the equipment into an outlet on a circuit different from that to which the receiver is connected.
- Consult the dealer or an experienced radio/TV technician for help.

CAUTION: Changes or modifications to this device not expressly approved by LOUD Technologies Inc. could void the user's authority to operate the equipment under FCC rules.

21. This apparatus does not exceed the Class A/Class B (whichever is applicable) limits for radio noise emissions from digital apparatus as set out in the radio interference regulations of the Canadian Department of Communications.

ATTENTION — *Le présent appareil numérique n'émet pas de bruits radioélectriques dépassant les limites applicables aux appareils numériques de class A/de class B (selon le cas) prescrites dans le règlement sur le brouillage radioélectrique édicté par les ministere des communications du Canada.*

22. Exposure to extremely high noise levels may cause permanent hearing loss. Individuals vary considerably in susceptibility to noise-induced hearing loss, but nearly everyone will lose some hearing if exposed to sufficiently intense noise for a period of time. The U.S. Government's Occupational Safety and Health Administration (OSHA) has specified the permissible noise level exposures shown in the following chart.

According to OSHA, any exposure in excess of these permissible limits could result in some hearing loss. To ensure against potentially dangerous exposure to high sound pressure levels, it is recommended that all persons exposed to equipment capable of producing high sound pressure levels use hearing protectors while the equipment is in operation. Ear plugs or protectors in the ear canals or over the ears must be worn when operating the equipment in order to prevent permanent hearing loss if exposure is in excess of the limits set forth here:

Duration, per day in hours	Sound Level dBA, Slow Response	Typical Example
8	90	Duo in small club
6	92	
4	95	Subway Train
3	97	
2	100	Very loud classical music
1.5	102	
1	105	Greg screaming at Troy about deadlines
0.5	110	
0.25 or less	115	Loudest parts at a rock concert

CAUTION

RISK OF ELECTRIC SHOCK! DO NOT OPEN!

CAUTION: TO REDUCE THE RISK OF ELECTRIC SHOCK DO NOT REMOVE COVER (OR BACK). NO USER-SERVICEABLE PARTS INSIDE. REFER SERVICING TO QUALIFIED PERSONNEL.



The lightning flash with arrowhead symbol within an equilateral triangle is intended to alert the user to the presence of uninsulated "dangerous voltage" within the product's enclosure, that may be of significant magnitude to constitute a risk of electric shock to persons.



The exclamation point within an equilateral triangle is intended to alert the user of the presence of important operating and maintaining (servicing) instructions in the literature accompanying the appliance.

WARNING — To reduce the risk of fire or electric shock, do not expose this apparatus to rain or moisture.

CAUTION — To prevent electric shock hazard, do not connect to mains power supply while grille is removed.



Correct disposal of this product: This symbol indicates that this product should not be disposed of with your household waste, according to the WEEE directive (2012/19/EU) and your national law. This product should be handed over to an authorized collection site for recycling waste electrical and electronic equipment (EEE). Improper handling of this type of waste could have a possible negative impact on the environment and human health due to potentially hazardous substances that are generally associated with EEE. At the same time, your cooperation in the correct disposal of this product will contribute to the effective usage of natural resources. For more information about where you can drop off your waste equipment for recycling, please contact your local city office, waste authority, or your household waste disposal service.

Laitte on liitettävä suojakoskettimilla varustettuun pistorasiaan.

Apparatet må tilkoples jordet stikkontakt.

Apparaten skall anslutas till jordat uttag.

Contents

- Important Safety Instructions 2
- Contents..... 3
- Features 3
- Introduction 4
- How To Use This Manual 4
- Getting Started..... 4
- Things To Remember..... 4
- Hookup Diagrams..... 5

- Thump12 / Thump15: Rear Panel Features..... 9
 - 1. Power Connection 9
 - 2. Power Switch..... 9
 - 2. Power LED..... 9
 - 4. XLR and 1/4" Combo Inputs..... 9
 - 5. Thru Output..... 10
 - 6. Level Knob / OL LED..... 10
 - 7. Low EQ 11
 - 8. Mid EQ..... 11
 - 9. Mid Freq 11
 - 10. Hi EQ 11
- Final Thoughts 11

- Placement..... 11
- Care and Maintenance 11

- Protection Circuitry 12
 - Limiting 12
 - Overexcursion Protection 12
 - Thermal Protection..... 12
- AC Power 12

- Appendix A: Service Information 13
- Appendix B: Connections 14
- Appendix C: Technical Information 15
 - Thump12 / Thump15 Dimensions..... 16
 - Thump12 / Thump15 Frequency Response..... 17
 - Thump12 / Thump15 Block Diagram 18

- Limited Warranty 19

Features

- 1000W Total System Power
 - Gig-ready, high-output design
 - Ultra-efficient Class-D amplification

- Class-leading, Chest-thumping Low End
 - 12" high-output woofer [Thump12]
 - 15" high-output woofer [Thump15]
 - 1.4" Titanium dome compression driver
 - Dynamic bass response delivers amazing lows at all volumes

- Total System Optimization
 - Precision 2-way crossover
 - Transducer time alignment
 - System protection / limiting

- Application Flexible
 - 3-band EQ with sweepable mid to dial in the perfect sound
 - Mic/line input allows direct connection of microphone
 - Flexible mounting options including tripod and pole-mounting
 - Angled design perfect for use as a stage monitor

- Lightweight and Portable
 - Rugged polypropylene construction designed for heavy use
 - 29.0 lb / 13.2 kg [Thump12]
 - 33.2 lb / 15.1 kg [Thump15]

Please write the serial numbers here for future reference (i.e., insurance claims, tech support, return authorization, make dad proud, etc.)

Purchased at:

Date of purchase:



Like us



Follow us



Watch our dang videos

Introduction

Only Thump Powered Loudspeakers deliver the class-leading, chest-thumping low end you deserve. Each Thump loudspeaker delivers 1000 watts of power, providing the high-output you need in a package that's tough, lightweight and portable.

Designed by the world's leader in portable live sound, Thump loudspeakers offer a 3-band EQ for dialing in the ideal sound. And with a rugged enclosure and robust system protection, you're more than ready for the next gig.

Delivering real-world power levels, application flexibility and class-leading bass response, you can be confident that Thump loudspeakers offers the best performance for your money.

How to Use This Manual:

After this introduction, a getting started guide will help you get things set up fast. The hookup diagrams show some typical Thump12 and Thump15 setups, including some that involve the Thump18S subwoofer.



This icon marks information that is critically important or unique to the subwoofer. For your own good, read and remember them.

Getting Started

The following steps will help you set up the loudspeakers quickly.

1. Make all initial connections with the power switches OFF on all equipment. Make sure the master volume, level and gain controls are all the way down.
2. If using a subwoofer, connect the outputs from the mixing console (or other signal source) to the inputs on the rear panel of the subwoofer, then connect the high pass outputs from the subwoofer to the inputs of the loudspeakers. Make sure the subwoofer's gain knob is set to "U" (unity gain).
3. If not using a subwoofer, connect the outputs from the mixing console (or other signal source) to the inputs on the rear panel of the loudspeakers.
4. Make sure the loudspeaker's level knob is set to "U" (unity gain).
5. Push the line cord securely into the subwoofer's/loudspeaker's IEC connectors and plug the other ends into grounded AC outlets. The subwoofer/loudspeaker may accept the appropriate voltage as indicated near the IEC connector.
6. Turn the mixer (or other signal source) on.
7. Turn the subwoofer on.
8. Turn the loudspeakers on.
9. Start the signal source and raise the mixer's main L/R fader up to a comfortably loud listening level.

Things to Remember:

- Never listen to loud music for prolonged periods. Please see the Safety Instructions on page 2 for information on hearing protection.
- As a general guide, the mixer (or other signal source) should be turned on first, subwoofers next, and Thump loudspeakers last. As such, the Thump loudspeakers should also be turned off first, followed by the subwoofers, then the mixer. This will reduce the possibility of any turn-on or turn-off thumps and other noises generated by any upstream equipment from coming out of the speakers.
- Save the shipping boxes and packing materials! You may need them someday. Besides, the cats will love playing in them and jumping out at you unexpectedly. Remember to pretend like you are surprised!
- Save your sales receipt in a safe place.

Hookup Diagrams

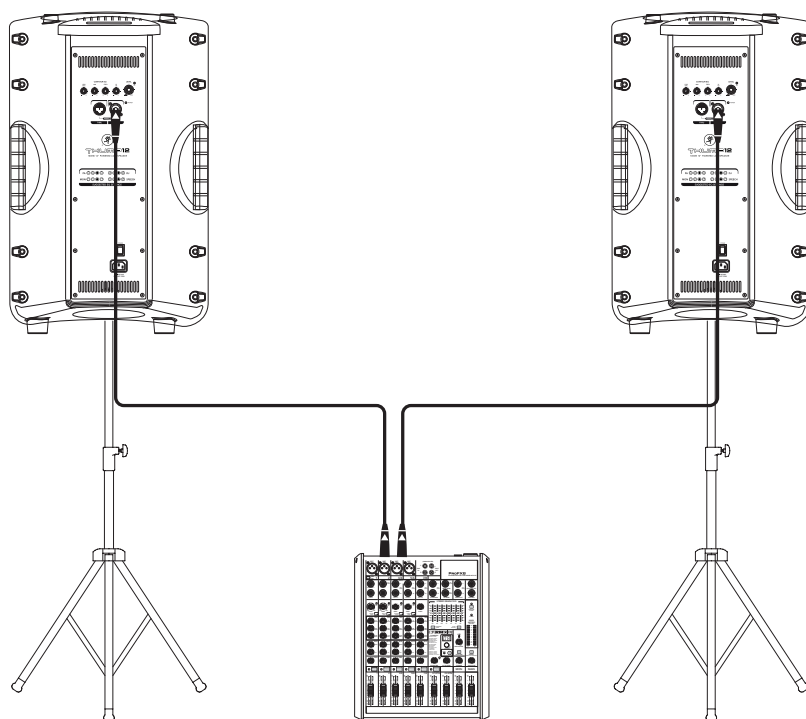

In this example, a ProFX8 mixer is connected directly to two Thump12 loudspeakers. It is the perfect setup for a small club. Simply connect the L/R outputs of the ProFX8 mixer to the inputs of each Thump12 loudspeaker.

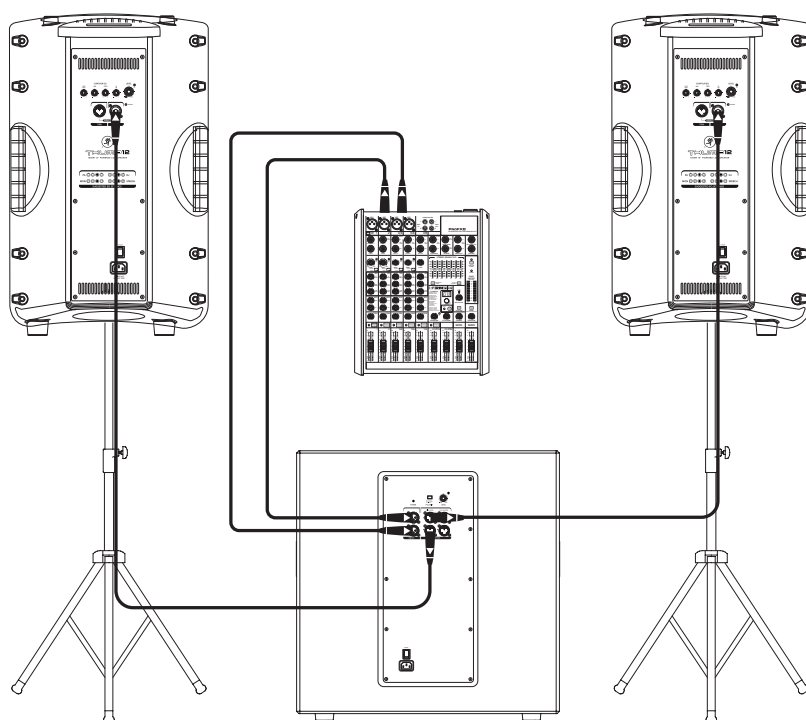

If you desire a little more boom, add a Thump18S subwoofer to the mix. Here, the L/R outputs of a ProFX8 mixer are connected directly to the channel A and B inputs of a single Thump18S subwoofer.

The channel A and B high pass outputs of the Thump18S subwoofer are connected directly to the inputs of each Thump12 loudspeaker.

Small Club System

Hookup Diagrams continued...

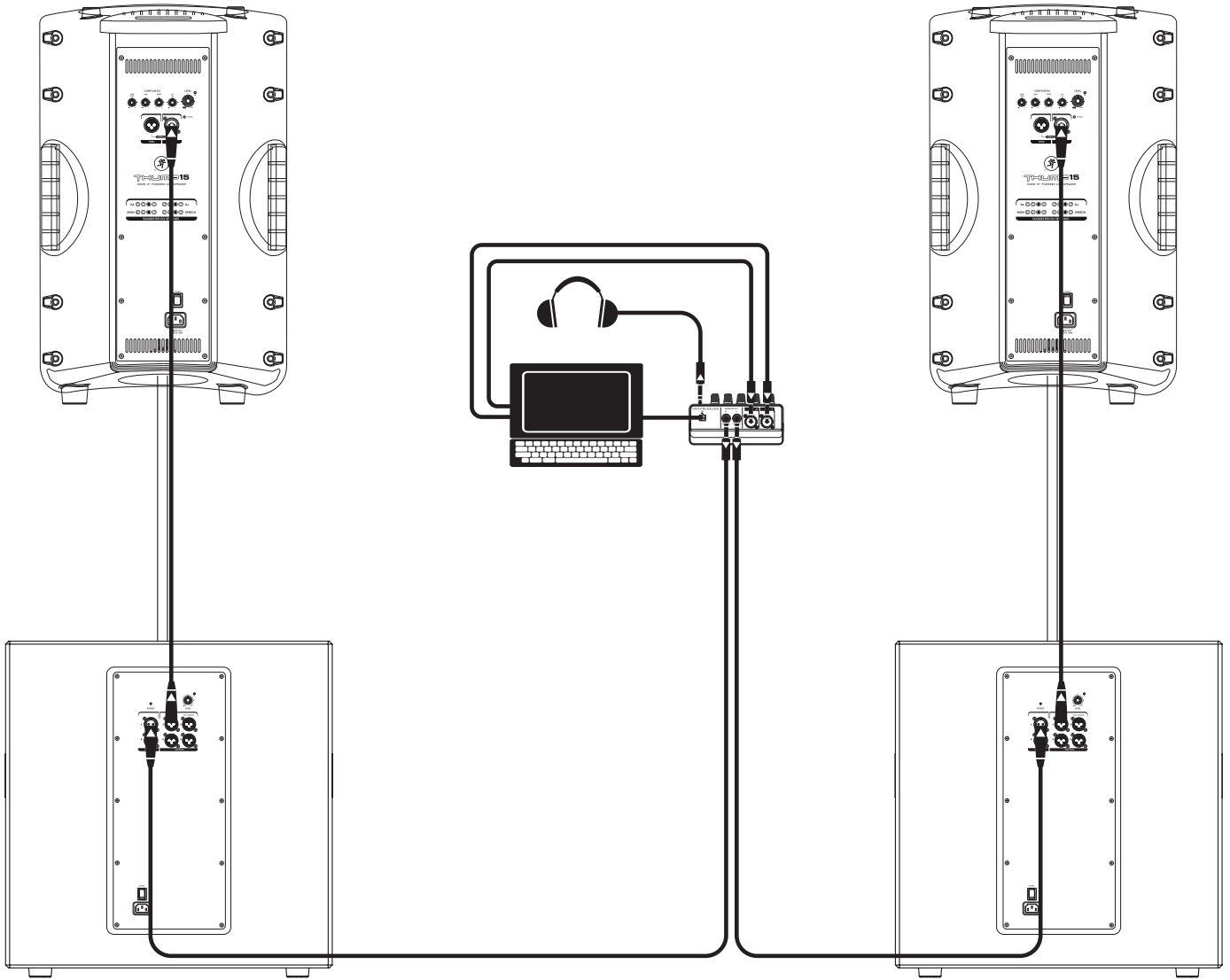

Perhaps you're a DJ playing bumpin' tunes in the middle of the night to a crowd that's groovin' and dancin' to your fine selection.

In this example, a laptop is connected to the channel 1 and 2 inputs of an Onyx Blackjack and a set of headphones are connected to the phones jack.

The L/R monitor outputs of the Onyx Blackjack are connected directly to the channel A inputs of each Thump18S subwoofer.

The channel A high pass output of each Thump18S subwoofer is connected directly to the input of each Thump15 loudspeaker.

DJ System

Hookup Diagrams continued...

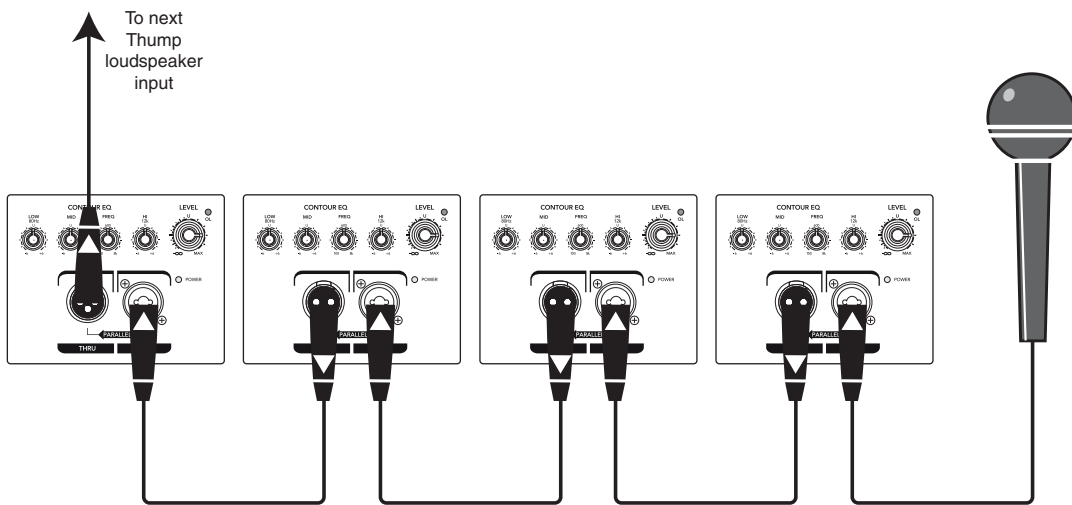
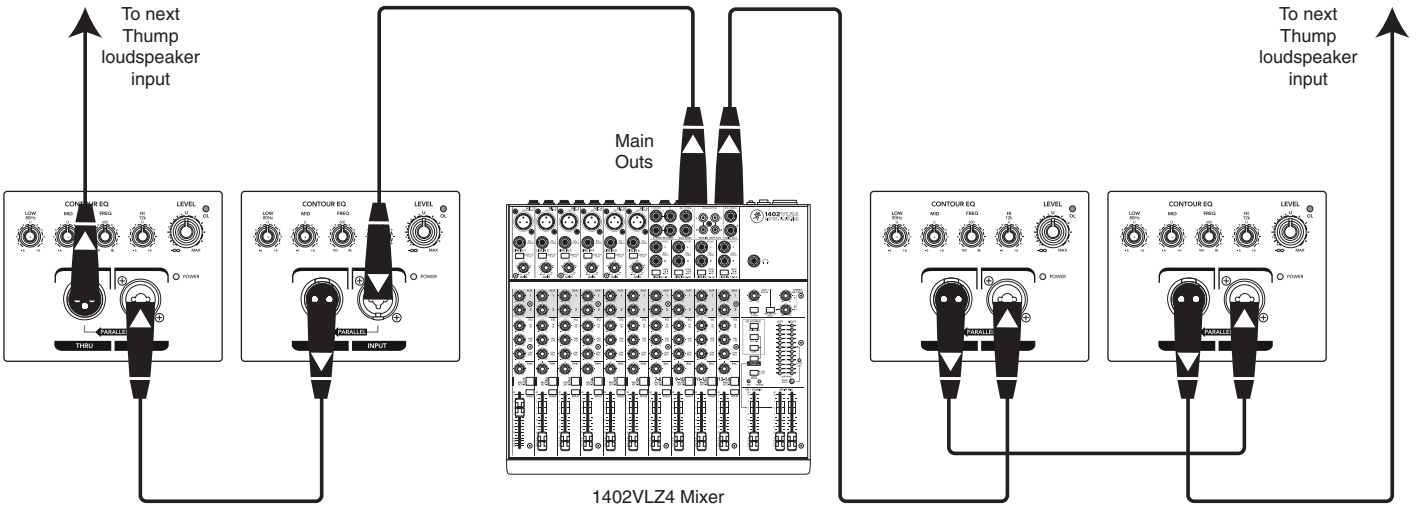

Thump loudspeakers may be daisy-chained via the male XLR connector labeled "THRU". Simply plug the signal source (i.e., mixer output or microphone) into the input jack(s), and patch that loudspeaker's thru jack to the next loudspeaker's input jack, and so on, daisy-chaining multiple Thump loudspeakers. See above for visual representations of daisy-chaining.

Daisy-Chaining Multiple Thump Loudspeakers

Hookup Diagrams continued...

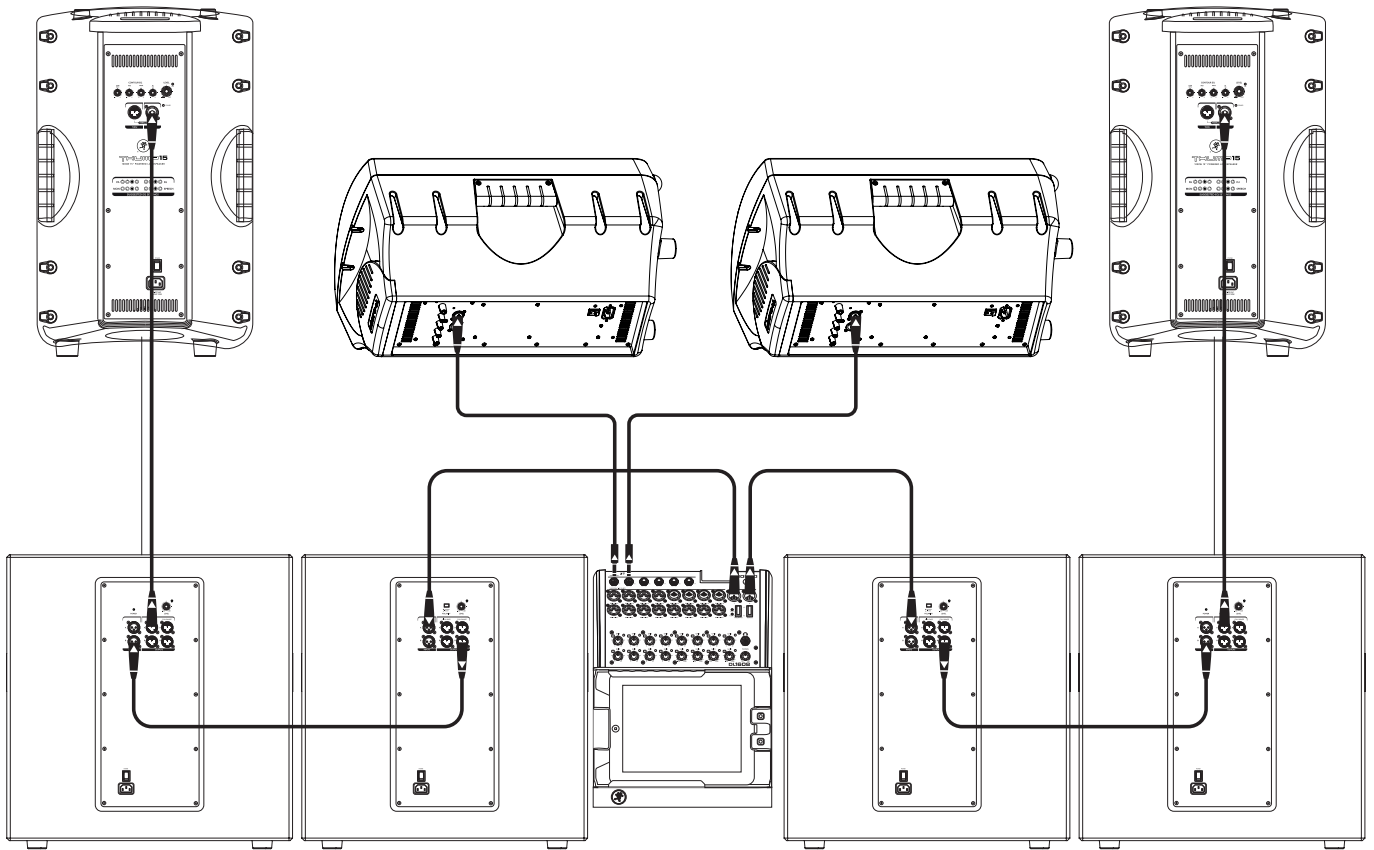

Here's how to set up a large club system. In this example, the L/R outputs of a DL1608 mixer are connected directly to the channel A inputs of two Thump18S subwoofers. The channel A full range outputs of these two Thump18S subwoofers are connected directly to the channel A inputs of another set of Thump18S subwoofers. Talk about beefy low end...and we've only connected the subs!

The channel A high pass outputs of the last two Thump18S subwoofers are connected directly to the inputs of the main pair of Thump15 loudspeakers.

The aux 1 and aux 2 sends from the mixer are connected directly to the inputs of a pair of Thump12 loudspeakers to be used as monitors for the band.

Large Club System

Thump12 / Thump15 Loudspeakers: Rear Panel Features

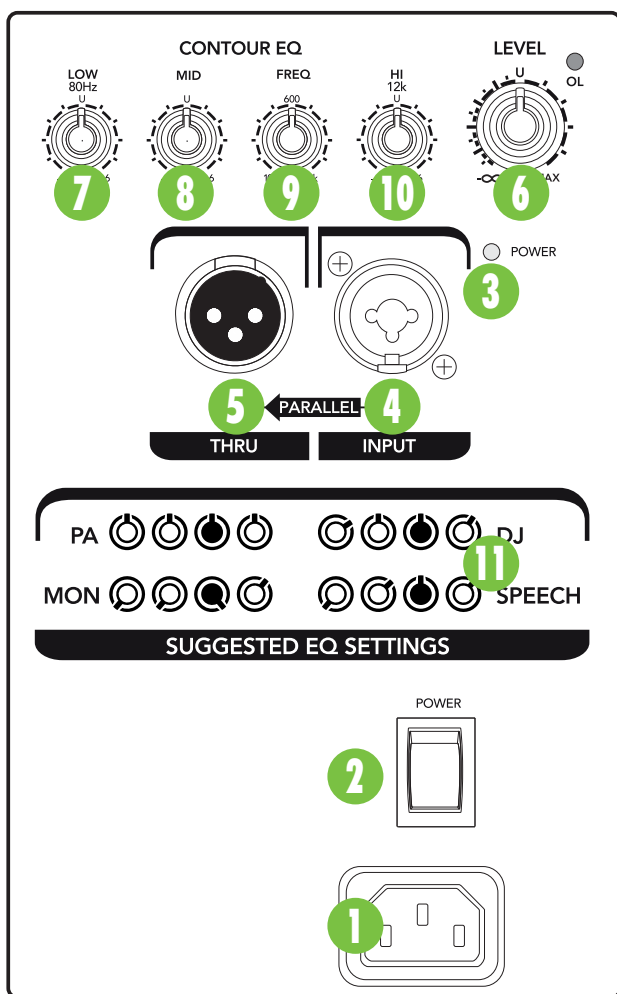

1. Power Connection

This is a standard 3-prong IEC power connector. Connect the detachable power cord (included in the packaging with the loudspeaker) to the power receptacle, and plug the other end of the power cord into an AC outlet.



Make sure that the AC power is matched to the AC power indicated on the rear panel (below the IEC receptacle).



Disconnecting the plug's ground pin is dangerous. Don't do it!

2. Power Switch

Press the top of this rocker switch inwards to turn on the loudspeaker. Press the bottom of this rocker switch inwards to turn off the loudspeaker.



As a general guide, the mixer (or other signal source) should be turned on first, subwoofers next, and loudspeakers last.

As such, the loudspeakers should also be turned off first, followed by the subwoofers, then the mixer. This will reduce the possibility of any turn-on or turn-off thumps and other noises generated by any upstream equipment from coming out of the speakers.

3. Power LED

When the power switch is turned on – and the power cord is connected to an active AC mains supply – this LED illuminates green to indicate that the loudspeaker is indeed really on. The cool green LED on the front of the loudspeaker works the same way.

4. XLR and 1/4" Combo Inputs

The input on Thump loudspeakers is a combo jack that may accept balanced/unbalanced XLR and 1/4" connections. The input may handle anything from a microphone to a line-level signal such as from a mixer. Simply connect an XLR, TRS or TS connector into the channel and adjust the level accordingly.



NEVER connect the output of an amplifier directly to the input of the loudspeaker.

This could damage the input circuitry of the active loudspeaker.

XLR connectors are wired as follows, according to standards specified by the AES (Audio Engineering Society):

Balanced XLR Input Connector

- Pin 1 – Shield (ground)
- Pin 2 – Positive (+ or hot)
- Pin 3 – Negative (– or cold)

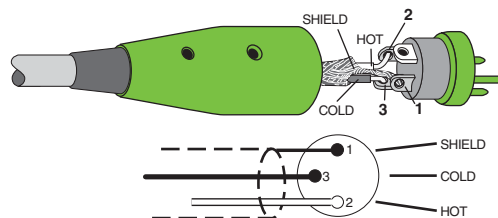

Balanced XLR Input Connector

Thump12 / Thump15 Loudspeakers: Rear Panel Features continued...

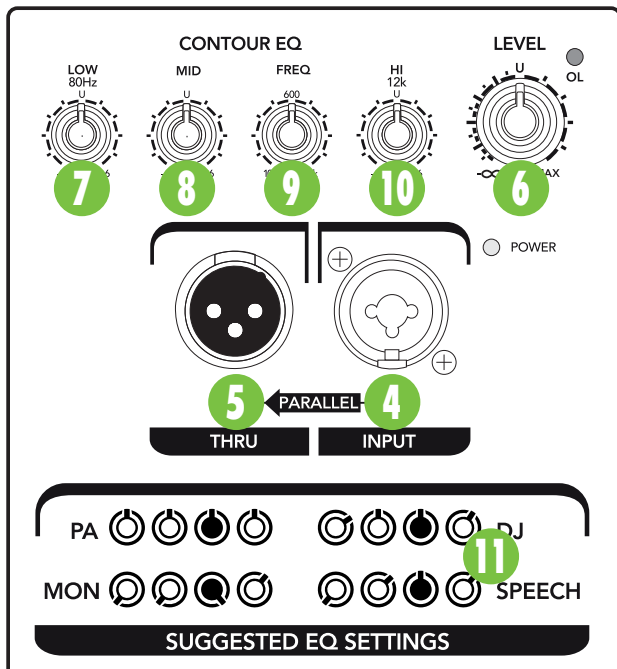

To connect a balanced line to this input, use a 1/4" Tip-Ring-Sleeve (TRS) plug. "TRS" stands for Tip-Ring-Sleeve, the three connection points available on a stereo 1/4" or balanced phone jack or plug. TRS jacks and plugs are used for balanced signals and stereo headphones and are wired as follows according to standards specified by the AES (Audio Engineering Society):

Balanced 1/4" TRS Connector

Sleeve – Shield (ground)
 Tip – Positive (+ or hot)
 Ring – Negative (- or cold)

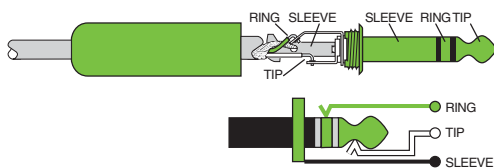

Balanced 1/4" TRS Connector

To connect an unbalanced line to this input, use a 1/4" mono (TS) phone plug, wired as follows according to standards specified by the AES (Audio Engineering Society):

Unbalanced 1/4" TS Connector

Sleeve – Shield (ground)
 Tip – Positive (+ or hot)

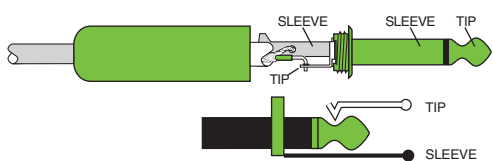

Unbalanced 1/4" TS Connector

For more information on these connectors, see Appendix B on page 14.

5. Thru Output

This is a male XLR-type connector that produces exactly the same signal that is connected to the input jack. Use it to daisy-chain several Thump loudspeakers together off the same signal source(s).

They are wired as follows, according to standards specified by the AES (Audio Engineering Society):

Balanced XLR Output Connector

Pin 1 – Shield (ground)
 Pin 2 – Positive (+ or hot)
 Pin 3 – Negative (- or cold)

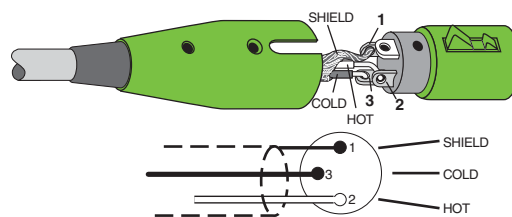

Balanced XLR Output Connector

See page 7 to learn more about daisy-chaining Thump loudspeakers.

For more information on these connectors, see Appendix B on page 14.

6. Level Knob / OL LED

The level knob adjusts the overall signal level at the input to the built-in power amplifiers. It ranges from Off (-∞) to MAX (maximum gain), with unity gain at the center position (12 o'clock).

- Thump loudspeakers are designed to operate with a +4 dBu signal when the level knob is at the U (center) position.

- Thump loudspeakers may accept up to a +20 dBu signal by turning down the level knob accordingly. Turning the level knob past unity will provide enough gain to connect a microphone directly.



NEVER connect the output of an amplifier directly to the input of the loudspeaker.

This could damage the input circuitry of the active loudspeaker.

The accompanying OL (overload) indicator illuminates red when the amplifier in the Thump loudspeaker is near the clipping point. It is OK if the OL LED blinks occasionally, because this means that the transient peaks are just reaching the maximum output of the amplifier and you are getting the most out of the loudspeaker.

Thump12 / Thump15 Loudspeakers: Rear Panel Features continued...

However, if the OL LED is blinking frequently or continuously, turn down the level control on the Thump loudspeaker or turn down the signal at its source (e.g., the mixing console) until the OL LED blinks occasionally or not at all.

7. Low EQ

This control provides up to 6 dB of boost or cut below 80 Hz and it is also flat at the center position (U). This frequency range represents the punch in bass drums, bass guitar, fat synth patches, and some really serious male singers.

8. Mid EQ

This is a midrange EQ control that provides 6 dB of boost or cut centered at any frequency between 100 Hz and 8 kHz. The MID EQ circuit is flat (no boost or cut) at the center position (U). This frequency range includes most vocals (male at the lower end of the range and female at the upper end of the range), and the fundamentals and harmonics for many instruments.

9. Mid Freq

This knob ranges from 100 Hz to 8 kHz and determines the center frequency for the Mid EQ filter. This allows you to zero in on the precise band of frequencies you want to have affected by the Mid EQ.

10. Hi EQ

This control gives you up to 6 dB boost or cut above 12 kHz. The circuit is flat (no boost or cut) at the center position (U). Use it to add sizzle to cymbals, and an overall sense of transparency or edge to the keyboards, vocals, guitar, and bacon frying. Turn it down a little to reduce sibilance, or to remove high frequency hiss.

11. Suggested EQ Settings

You might prefer a different overall tone depending on how you will be using the Thump loudspeakers. They are perfect for general PA use with the 3-band EQ set flat (all knobs at 12 o'clock). For other common applications, set the EQ knobs as shown, then adjust to taste from there.

Final Thoughts

The following pages discuss Thump loudspeaker placement, protection circuitry, technical information and much more. Check it out!

Placement

Thump loudspeakers are designed to sit on the floor or stage. They may also be pole-mounted via the built-in socket on the bottom of the cabinet. They are not designed to be suspended.

When pole-mounting Thump loudspeakers, be sure that the subwoofers are stabilized and secured from falling over or being accidentally pushed over. For stacked scenarios, it is highly suggested that straps are utilized. Failure to follow these precautions may result in damage to the equipment, personal injury, or death.



Thump loudspeaker cabinets have no rigging points and are not suitable for rigging. NEVER attempt to suspend a Thump loudspeaker by its handles.

As with any powered components, protect them from moisture and extreme cold and follow the other Care and Maintenance suggestions below.

Care and Maintenance

Your Thump loudspeakers will provide many years of reliable service if you follow these guidelines:

- Avoid exposing the loudspeakers to moisture. If they are set up outdoors, be sure they are under cover if rain is expected.
- Avoid exposure to extreme cold (below freezing temperatures). If you must operate the loudspeakers in a cold environment, warm up the voice coils slowly by sending a low-level signal through them for about 15 minutes prior to high-power operation.
- Use a dry cloth to clean the cabinets. Only do this when the power is turned off. Avoid getting moisture into any of the openings of the cabinet, particularly where the drivers are located.

Protection Circuitry

Thump loudspeakers employ a built-in limiter for less distortion at peak levels. A dynamic bass response circuit provides optimal low frequency response regardless of overall output level. Additional protection includes automatic thermal shutdown should the amp overheat. However, with Class-D amp technology, which is highly-efficient, this should never be a problem.



The protection circuits are designed to protect the loudspeakers under reasonable and sensible conditions. Should you choose to ignore the warning signs [e.g. excessive distortion], you can still damage the speaker in the loudspeaker by overdriving it past the point of amplifier clipping. Such damage is beyond the scope of the warranty.

Limiting

The driver has its own compression circuit which helps protect it from damaging transient peaks. The compressor is designed to be transparent and is not noticeable under normal operating conditions.

Overexcursion Protection

A subsonic filter circuit just prior to the power amplifier prevents ultra-low frequencies from being amplified. Excessive low-frequency energy can damage the woofer by causing it to “bottom out,” also known as overexcursion, which is equivalent to a mechanical form of clipping.

Thermal Protection

All amplifiers produce heat. Thump loudspeakers are designed to be efficient both electrically and thermally.

In the unlikely event of the amplifier overheating, a built-in thermal switch will activate, muting the signal.

When the amplifier has cooled down to a safe operating temperature, the thermal switch resets itself, and the Thump loudspeaker resumes normal operation.

If the thermal switch activates, try turning down the level control a notch or two on the mixing console (or the back of the loudspeaker) to avoid overheating the amplifier. Be aware that direct sunlight and/or hot stage lights may be the culprit of an amplifier overheating.

AC Power

Be sure the Thump loudspeaker is plugged into an outlet that is able to supply the correct voltage specified for your model. It will continue to operate at lower voltages, but will not reach full power.

Be sure the electrical service can supply enough amperage for all the components connected to it.

We recommend that a stiff (robust) supply of AC power be used because the amplifiers place high current demands on the AC line. The more power that is available on the line, the louder the speakers will play and the more peak output power will be available for a cleaner, punchier bass. A suspected problem of “poor bass performance” is often caused by a weak AC supply to the amplifiers.



Never remove the ground pin on the power cord or any other component of the Thump loudspeaker. This is very dangerous.

Appendix A: Service Information

If you think your Thump loudspeaker has a problem, please check out the following troubleshooting tips and do your best to confirm the problem. Visit the Support section of our website (www.720trees.com) where you will find lots of useful information such as FAQs and other documentation. You may find the answer to the problem without having to part with your subwoofer.

Troubleshooting

No power

- Our favorite question: Is it plugged in? Make sure the AC outlet is live [check with a tester or lamp].
- Our next favorite question: Is the power switch on? If not, try turning it on.
- Make sure the line cord is securely seated in the line cord socket and plugged all the way into the AC outlet.
- Is the power LED on the front and rear panel illuminated? If not, make sure the AC outlet is live. If so, refer to “No sound” below.
- The internal AC line fuse may be blown. This is not a user serviceable part. If you suspect the AC line fuse is blown, please see the "Repair" section next.

No sound

- Is the level knob for the input source turned all the way down? Verify that all the volume controls in the system are properly adjusted. Look at the level meter to ensure that the mixer is receiving a signal.
- Is the signal source working? Make sure the connecting cables are in good repair and securely connected at both ends. Make sure the output level control on the mixing console is turned up sufficiently to drive the inputs of the speaker.
- Make sure the mixer does not have a mute on or a processor loop engaged. If you find something like this, make sure the level is turned down before disengaging the offending switch.
- Has it shut down? Make sure there is at least six inches of free space behind each Thump loudspeaker.

Poor sound

- Is it loud and distorted? Make sure that you're not overdriving a stage in the signal chain. Verify that all level controls are set properly.
- Is the input connector plugged completely into the jack? Be sure all connections are secure.

Noise

- Make sure all connections to the active loudspeakers are good and sound.
- Make sure none of the signal cables are routed near AC cables, power transformers, or other EMI-inducing devices.
- Is there a light dimmer or other SCR-based device on the same AC circuit as the Thump loudspeaker? Use an AC line filter or plug the loudspeaker into a different AC circuit.

Hum

- Try disconnecting the cable connected to the input jack. If the noise disappears, it could be a “ground loop,” rather than a problem with the Thump loudspeaker. Try some of the following troubleshooting ideas:
- Use balanced connections throughout your system for the best noise rejection.
- Whenever possible, plug all the audio equipment's line cords into outlets which share a common ground. The distance between the outlets and the common ground should be as short as possible.

Repair

For warranty service, refer to the warranty information on page 19.

Non-warranty service is available at a factory-authorized service center. To locate the nearest service center, visit www.720trees.com, click “Contact Tech Support” and select “Locate a Service Center or Distributor” [3]. Service for Thump loudspeakers outside the United States can be obtained through local dealers or distributors.

If you do not have access to our website, you may call the Tech Support department at 1-800-898-3211, Monday-Friday, during normal business hours, Pacific Time, to explain the problem. Tech Support will tell you where the nearest factory-authorized service center is located in your area.

Appendix B: Connections

XLR and 1/4" Combo Input Connector

The input on Thump loudspeakers is a combo jack that may accept balanced/unbalanced XLR and 1/4" connections. The input may handle anything from an instrument level to a high-output mic signal. Simply connect an XLR, TRS or TS connector into the channel and adjust the level accordingly.

Balanced XLR Input Connector

If using balanced XLR input cables, be sure the cables are wired per AES (Audio Engineering Society) standards:

Balanced XLR Input Connector

- Pin 1 – Shield (Ground)
- Pin 2 – Positive (+ or hot)
- Pin 3 – Negative (– or cold)

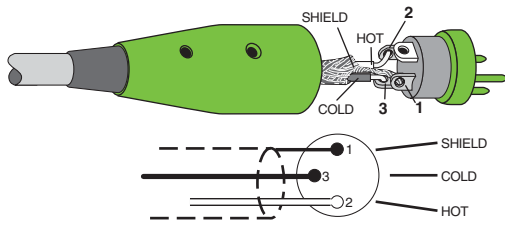

Balanced XLR Input Connector

Balanced 1/4" TRS Input Connector

To connect a balanced line to this input, use a 1/4" Tip-Ring-Sleeve (TRS) plug. “TRS” stands for Tip-Ring-Sleeve, the three connection points available on a stereo 1/4" or balanced phone jack or plug.

If using balanced 1/4" TRS input cables, be sure the cables are wired per AES (Audio Engineering Society) standards:

Balanced 1/4" TRS Connector

- Sleeve – Shield (ground)
- Tip – Positive (+ or hot)
- Ring – Negative (– or cold)

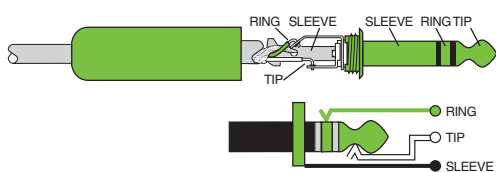

Balanced 1/4" TRS Connector

Unbalanced 1/4" TS Input Connector

To connect an unbalanced line to this input, use a 1/4" mono (TS) phone plug.

If using unbalanced 1/4" TS input cables, be sure the cables are wired per AES (Audio Engineering Society) standards:

Unbalanced 1/4" TS Connector

- Sleeve – Shield (ground)
- Tip – Positive (+ or hot)

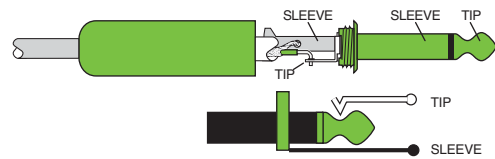

Unbalanced 1/4" TS Connector

Balanced XLR Output Connector

There is also one male balanced XLR output connector on each Thump loudspeaker. Be sure the cables are wired per AES (Audio Engineering Society) standards:

Balanced XLR Output Connector

- Pin 1 – Shield (Ground)
- Pin 2 – Positive (+ or hot)
- Pin 3 – Negative (– or cold)

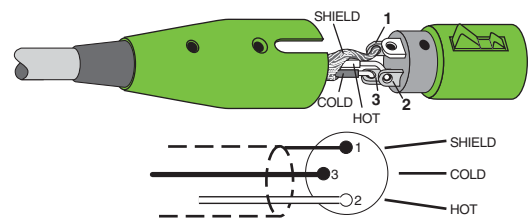

Balanced XLR Output Connector

Thump loudspeakers may be daisy-chained via the male XLR connector labeled “THRU”. Simply plug the signal source (i.e., mixer output) into the input jack(s), and patch that loudspeaker’s thru jack to the next loudspeaker’s input jack, and so on, daisy-chaining multiple Thump loudspeakers. See page 7 for a visual representation of daisy-chaining.

Appendix C: Technical Information

Thump12 / Thump15 Loudspeakers Specifications

Acoustic Performance

Frequency Range (-10 dB):	50 Hz – 23 kHz [Thump12] 32 Hz – 23 kHz [Thump15]
Frequency Range (-3 dB):	57 Hz – 20 kHz [Thump12] 39 Hz – 20 kHz [Thump15]
Horizontal Coverage Angle:	90°
Vertical Coverage Angle:	60°
Maximum SPL Peak:	125 dB SPL @ 1m [Thump12] 126 dB SPL @ 1m [Thump15]
Monitor Angle	50° [Thump12] 45° [Thump15]

Transducers

Low Frequency:	12 in / 305 mm [Thump12] 15 in / 381 mm [Thump15] with steel frame, paper cone woofer
High Frequency:	1.4 in / 36 mm Titanium dome compression driver

Power Amplifiers

Low Frequency Power Amplifier

Rated Power:	400 watts rms 800 watts peak
Design:	Class D

High Frequency Power Amplifier

Rated Power:	100 watts rms 200 watts peak
Design:	Class AB

Input/Output

Input Type:	Female XLR / 1/4" Balanced
Input Impedance:	20 kΩ balanced bridging; 10 kΩ unbalanced
Thru:	Male XLR Balanced
Level Control:	Rotating knob 0 dB at center
Sensitivity:	+4 dBu for full output (Level Control @ Center) -36 dBu for full output (Level Control @ Max)

Electronic Crossover

Crossover Type:	24 dB/octave
Crossover Frequency:	3 kHz

Equalization

Low Frequency EQ:	±6 dB @ 80 Hz, shelving
Mid Frequency EQ:	±6 dB sweepable from 100 Hz to 8 kHz
High Frequency EQ:	±6 dB @ 12 kHz, shelving

Line Input Power

US:	100 – 120 VAC, 50 – 60 Hz 130 watts
EU:	220 – 240 VAC, 50 – 60 Hz 130 watts
AC Connector:	3-pin IEC 250 VAC, 10 A male

Safety Features

Peak and RMS limiting, power supply and amplifier thermal protection

Construction Features

Basic Design:	Trapezoidal
Material:	Polypropylene
Finish:	Textured
Handles:	One on each side, one on top
Grille:	Perforated metal with weather-resistant coating
Display LEDs	
Front:	Power ON
Rear:	Power ON, OL (overload)
Operating Temperature:	0 – 40 °C 32 – 104 °F

Physical Properties

Thump12:

Height:	23.5 in / 596 mm
Width:	14.5 in / 367 mm
Depth:	12.4 in / 314 mm
Weight:	29.0 lb / 13.2 kg

Thump15:

Height:	27.6 in / 702 mm
Width:	16.8 in / 427 mm
Depth:	15.5 in / 394 mm
Weight:	33.2 lb / 15.1 kg

Mounting Methods:

Pole-mountable via the built-in socket on the bottom of the cabinet. Be sure the pole is capable of supporting the weight of the Thump loudspeaker.

Options

Thump12 Bag	P/N 2036809-07
Thump15 Bag	P/N 2036809-06
SPM200 Loudspeaker Pole Mount	P/N 2035170-01

Thump12 Loudspeaker Dimensions

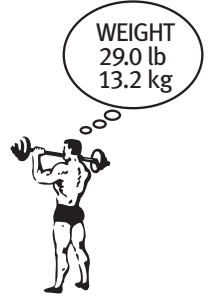
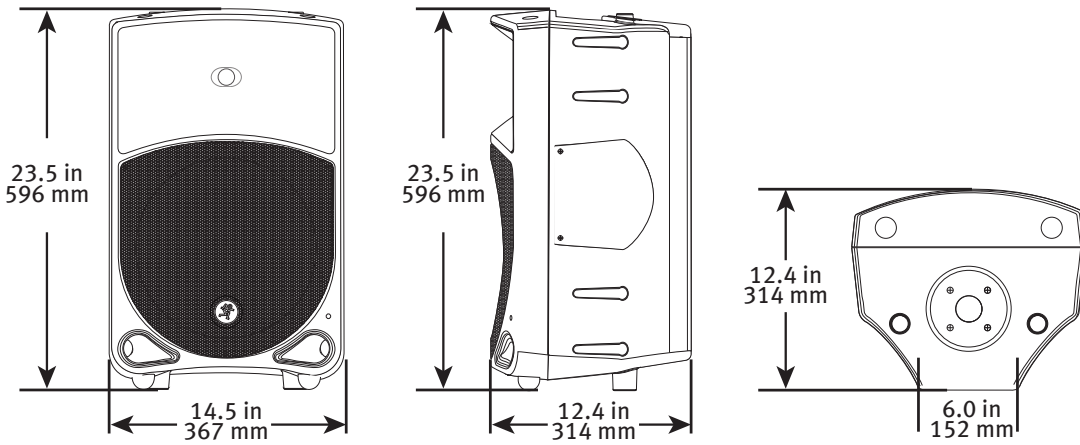

Thump15 Loudspeaker Dimensions

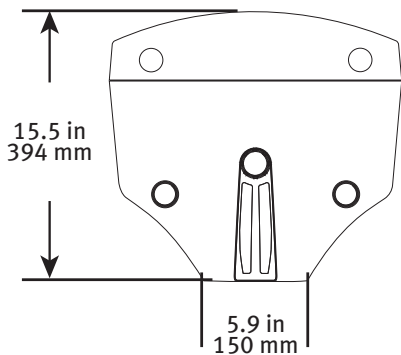
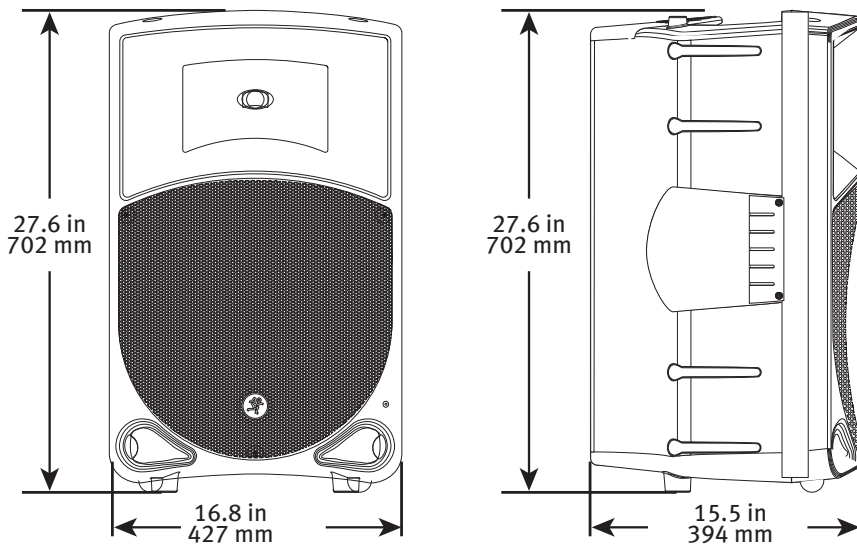

Disclaimer

Since we are always striving to make our products better by incorporating new and improved materials, components, and manufacturing methods, we reserve the right to change these specifications at any time without notice.

The "Running Man" figure is a registered trademark of LOUD Technologies Inc.

All other brand names mentioned are trademarks or registered trademarks of their respective holders, and are hereby acknowledged.

©2014 LOUD Technologies Inc.
All Rights Reserved.

Thump12 Loudspeaker Frequency Response

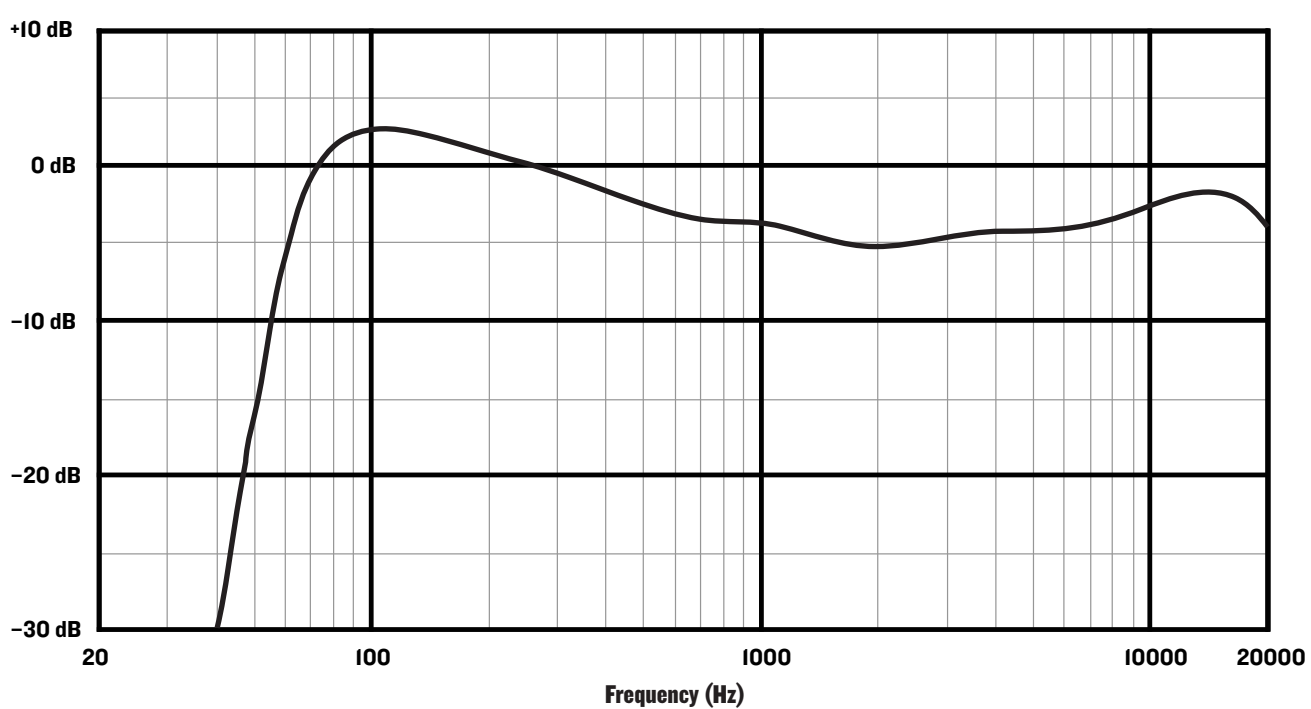

Thump15 Loudspeaker Frequency Response

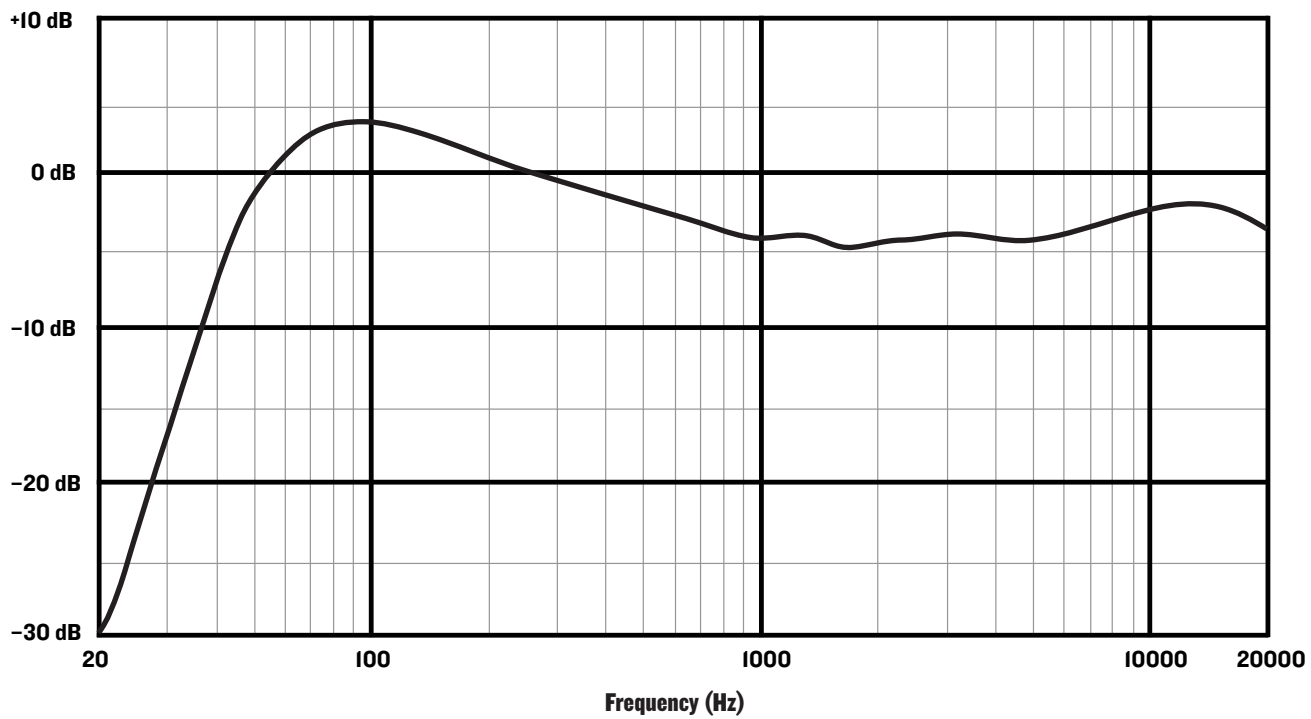

Thump12 / Thump15 Loudspeakers Block Diagram

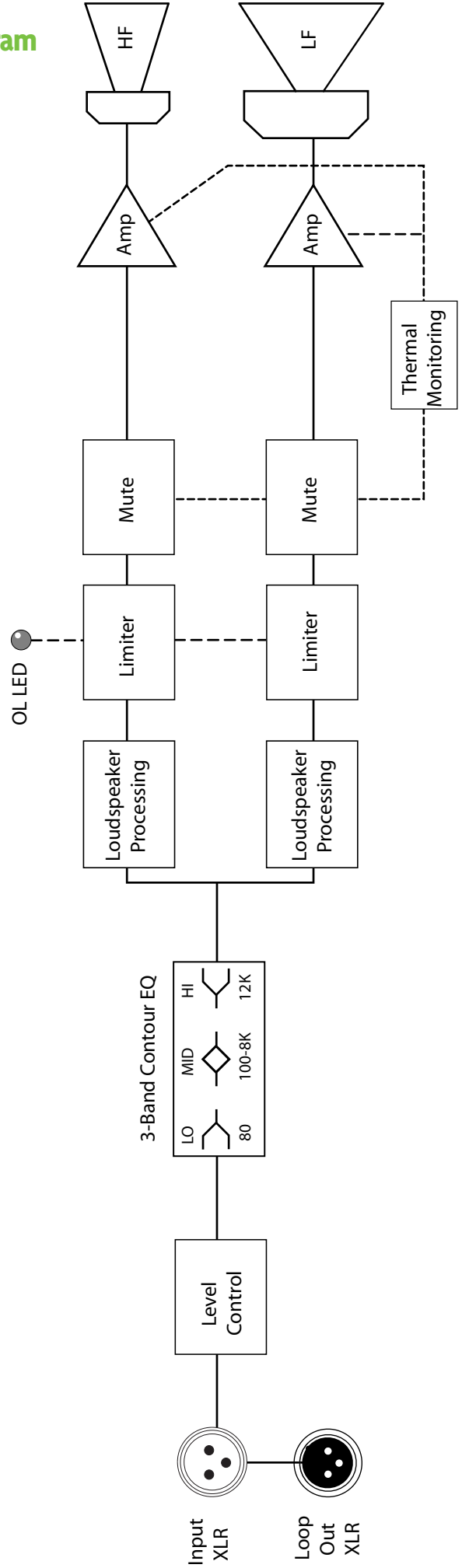

Limited Warranty

Please keep your sales receipt in a safe place.

This Limited Product Warranty ("Product Warranty") is provided by LOUD Technologies Inc. ("LOUD") and is applicable to products purchased in the United States or Canada through a LOUD-authorized reseller or dealer. The Product Warranty will not extend to anyone other than the original purchaser of the product (hereinafter, "Customer," "you" or "your").

For products purchased outside the U.S. or Canada, please visit www.720trees.com to find contact information for your local distributor, and information on any warranty coverage provided by the distributor in your local market.

LOUD warrants to Customer that the product will be free from defects in materials and workmanship under normal use during the Warranty Period. If the product fails to conform to the warranty then LOUD or its authorized service representative will at its option, either repair or replace any such nonconforming product, provided that Customer gives notice of the noncompliance within the Warranty Period to the Company at: www.720trees.com or by calling LOUD technical support at 1.800.898.3211 (toll-free in the U.S. and Canada) during normal business hours Pacific Time, excluding weekends or LOUD holidays. Please retain the original dated sales receipt as evidence of the date of purchase. You will need it to obtain any warranty service.

For full terms and conditions, as well as the specific duration of the Warranty for this product, please visit www.720trees.com.

The Product Warranty, together with your invoice or receipt, and the terms and conditions located at www.720trees.com constitutes the entire agreement, and supersedes any and all prior agreements between LOUD and Customer related to the subject matter hereof. No amendment, modification or waiver of any of the provisions of this Product Warranty will be valid unless set forth in a written instrument signed by the party to be bound thereby.

Need help with the loudspeaker?

- Visit www.720trees.com and click Support to find: FAQs, manuals, addendums, and other documents.
- Email us at: techmail@loudtechinc.com.
- Telephone 1-800-898-3211 to speak with one of our splendid technical support chaps (Monday through Friday, normal business hours, Pacific Time).



**16220 Wood-Red Road NE
Woodinville, WA 98072 • USA
Phone: 425.487.4333
Toll-free: 800.898.3211
Fax: 425.487.4337
www.720trees.com**
