

PROFESSIONAL SOUND SYSTEMS >>>

# **EZGO™ PORTABLE AMPLIFIER SYSTEM OPERATING MANUAL AND USER GUIDE**

EZ-USB    EZ-RDM    EZ-MIC    EZ-BAG



[www.wharfedalepro.com](http://www.wharfedalepro.com)

## IMPORTANT WARNINGS & SAFETY INSTRUCTIONS

1. Read these instructions
2. Follow all instructions
3. Keep these instructions
4. Heed all warnings
5. Do not use this apparatus near water
6. Clean only with dry cloth.
7. Do not block any ventilation openings. Install in accordance with the manufacturer's instructions.
8. Do not install near any heat sources such as radiators, heat registers, stoves, or other apparatus (including amplifiers) that produce heat.
9. Do not defeat the safety purpose of the polarized or grounding plug. A polarized plug has two blades with one wider than the other. A grounding plug has two blades and a third grounding prong. The wide blade or the third prong is provided for your safety. If the provided plug does not fit into your outlet, consult an electrician for replacement of the obsolete outlet.
10. Protect the power cord from being walked on or pinched particularly at the plugs, convenience receptacles, and at the point where they exit from the apparatus.
11. Only use attachments/accessories specified by the manufacturer.
12. Use only with a cart, stand, tripod, bracket, or table specified by the manufacturer, or sold with the apparatus. When a cart or rack is used, use caution when moving the cart and apparatus combination to avoid injury from tip-over.





13. Unplug the apparatus during lightning storms or when unused for long periods of time.
14. Refer all servicing to qualified personnel. Servicing is required when the apparatus has been damaged in any way including but not limited to power supply cord or plug damage, liquid ingress, foreign objects in the chassis, exposure to rain/moisture or impact damage. In addition the unit must be serviced when you experience any abnormal operation.
15. CAUTION: These servicing instructions are for use by qualified service personnel only. To reduce the risk of electric shock, do not attempt to perform any servicing other than that contained in the operating instructions unless you are qualified to do so. In addition opening the casing will result in your warranty becoming null and void.
16. Do not install this apparatus in a confined space such as a book case or similar unit. Good ventilation should be maintained around the apparatus and any vents, air-inlets or fans should not be obstructed by objects such as paper, table-cloths, curtains etc.
17. WARNING: To reduce the risk of fire or electric shock, do not expose the apparatus to rain or moisture. The apparatus should not be exposed to dripping or splashing and objects filled with liquids, such as vases, should not be placed on the apparatus.
18. WARNING: The mains plug/appliance coupler is used as a disconnect device, the disconnect device shall remain readily operable.



19. This lightning flash with arrowhead symbol within an equilateral triangle is intended to alert the user to the presence of non-insulated "dangerous voltage" within the product's enclosure that may be of sufficient magnitude to constitute a risk of electric shock.  
Warning: To reduce the risk of electric shock, do not remove the cover (or back) as there are no user-

serviceable parts inside. Refer servicing to qualified personnel.

The exclamation point within an equilateral triangle is intended to alert the user to the presence of important operating and maintenance instructions in the literature accompanying the appliance.

20.  (Protective earthing terminal) The apparatus should be connected to a mains socket outlet with a protective earthing connection.
21.  Correct Disposal of this product. This marking indicates that this product should not be disposed with other household wastes throughout the EU. To prevent possible harm to the environment or human health from uncontrolled waste disposal, recycle it responsibly to promote the sustainable reuse of material resources. To return your used device, please use local return and collection systems or contact the retailer where the product was purchased.  
They can take this product for safe environmentally friendly recycling.
22. **Warning:** People who are implanted with an electronic cardiac pacemaker or AICD device (Automated Implantable Cardioverter Defibrillator) should pay attention to the following items:  
Any radiation source may cause interference to the normal function of this kind of implanted devices. The output power of all the wireless microphones' transmitters normally is very low (less than 0.05W). And usually it will not cause any disorder, especially when the wireless microphones are several inches away from the implanted devices. When the RF is powered off, all the possible interference will be stopped. If you are disturbed with any problems when using this system or any other RF devices, please consult your doctor or your medical device dealer.

**Attention:** To ensure its optimal quality and also to comply with the related statutory rules, the inner circuits of the receivers have been adjusted accurately. Please do not attempt to open or disassemble the receivers and transmitters. It may invalidate your warranty and even may cause malfunctions.

- \* To reduce the risk of electric shock, please don't remove the cover. Refer all servicing to qualified service personnel.
- \* Please don't expose this product to dripping and splashing.
- \* No objects filled with liquids such as a vase of flowers should be placed on the product.
- \* Please don't keep this device running in a narrow space(such as a book cabinet).
- \* Please keep the device free access to the AC power supply, so that it can be disconnected immediately if any emergency happens.
- \* Please keep the wireless microphone transmitter dry and avoid exposure to extreme temperatures or humidity.

## **TABLE OF CONTENTS**

IMPORTANT WARNINGS & SAFETY INSTRUCTIONS.....	1
INTRODUCTION .....	3
KEY FEATURES .....	3
OPERATING INSTRUCTIONS.....	5
FRONT PANEL LAYOUT .....	12
DIMENSION DRAWING.....	13
SPECIFICATIONS .....	14
BEFORE YOU ASK FOR REPAIR SERVICES .....	15
APPENDIX I: FREQUENCY CODE LIST.....	16
APPENDIX II: ADDITIONAL USB SPECIFICATION .....	18

## INTRODUCTION

Thank you for purchasing EZ-GO portable amplifier system. EZ-GO can be configured a number of different ways with EZ-GO function modules\* to suit your specific needs.

EZ-GO is ideally suited to cover large areas such as class rooms and conference rooms. This manual covers the complete function and operation of the unit.

\* Function modules include a USB Input module and a wireless microphone Receiver/Transmitter module.

## KEY FEATURES

### Main Unit (EZGO)

- ◆ Two 5" full range drivers with 1" voice coils
- ◆ Formed aluminum cone diaphragm provides outstanding heat transmission of driver
- ◆ 15 oz ferrite magnet for high sound performance
- ◆ Tuned port tube design for increased bass performance
- ◆ Portable case with extendable handle
- ◆ Optional Wireless Microphone Transmitter/Receiver, Weather Proof Bag and USB module
- ◆ XLR mic input with gain control
- ◆ RCA unbalanced line level input with gain control
- ◆ 2 red peak LEDs for XLR mic and RCA line input
- ◆ 3 LEDs (Green, Orange & Red) to indicate the battery level, 1 red LED to indicate the connection status of battery
- ◆ 1 green LED to indicate the existence of external power
- ◆ 3 band EQ control
- ◆ Master volume control with power on/off switch
- ◆ 70W RMS power output, 140W peak power
- ◆ Power supply from DC jack or IEC AC receptacle
- ◆ Switching mode power supply - works world wide.

### Optional USB Module (EZ-USB)

- ◆ Master volume control with on/off switch
- ◆ Infra-red receiver
- ◆ LCD display
- ◆ 4 control buttons: STOP, PLAY, FAST FORWARD & BACK
- ◆ USB Drive for MP3/WMA playback
- ◆ USB To PC interfacing with PC or MAC
- ◆ Remote Control

### **Optional Wireless Microphone Receiver (EZ-RDM)**

- ◆ **Master volume control with on/off switch**
- ◆ **Infra-red emitter**
- ◆ **LCD display**
- ◆ **4 control buttons: Scan 1, Sync 1, Scan 2 & Sync 2**
- ◆ **Channel indicator**
- ◆ **1 wireless microphone transmitter included**

### **Optional Wireless Microphone Transmitter (EZ-MIC)**

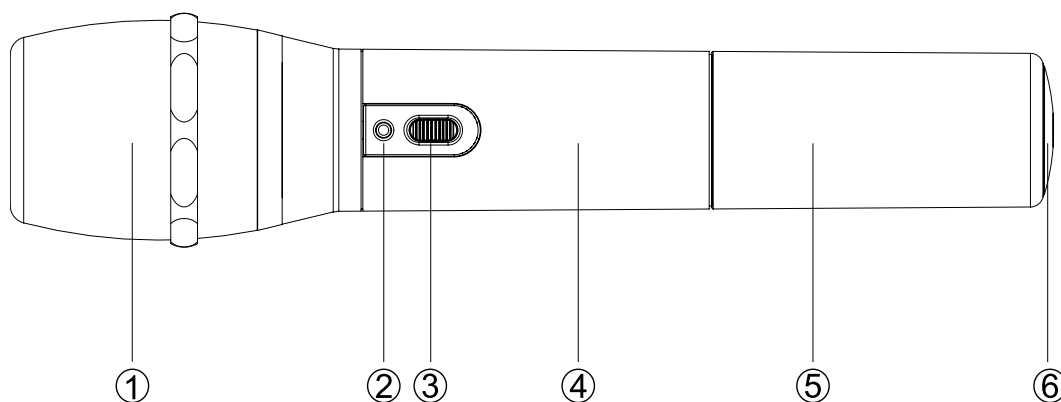

1. **Mesh head**
2. **Power indicator with constant illumination indicates that power is supplied and it is working normally. A flashing indicator means power is low and the battery needs changing.**
3. **Power switch**
4. **Front handle contains mechanical parts and inner PCB board**
5. **Back handle contains the battery container and aerial**
6. **IR Receiving window for synchronization with receiver**

### **Optional Weatherproof Bag (EZ-BAG)**

- ◆ **Detachable speaker cover allows EZGO to operate without removing the bag.**
- ◆ **Velcro flap folds down for access to controls.**
- ◆ **Velcro flap provides access to telescoping handle and carrying handle.**
- ◆ **Detachable mic bag**
- ◆ **Zipper pouch for remote control and USB sticks**

# OPERATING INSTRUCTIONS

## Main Unit

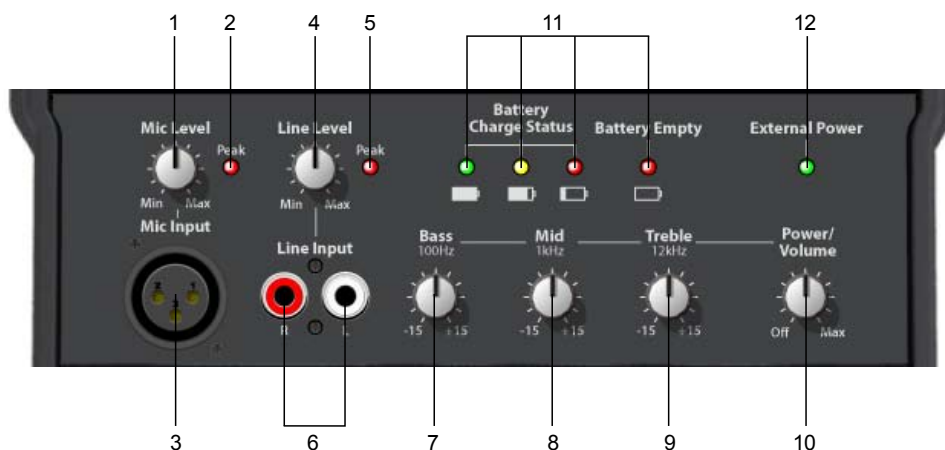

1. Mic Level  
Controls the volume of wired Mic input.
2. Mic Level Peak indicator  
LED illuminates when the Mic input signal is too high.
3. Mic Input  
To connect a Mic with XLR connector
4. Line Level  
Controls the volume of Line input
5. Line Level Peak indicator  
LED illuminates when the Line input signal is too high.
6. Line input jack  
To connect the unit to other media players via RCA cables.
7. Bass  
100Hz bass EQ adjustment. Attenuation/amplification adjustment  $\pm 15$ dB.
8. Mid  
1KHz Mid EQ adjustment. Attenuation/amplification adjustment  $\pm 15$ dB.
9. Treble  
12kHz treble EQ adjustment. Attenuation/amplification adjustment  $\pm 15$ dB.
10. Power/Volume  
Controls the output power from the power supply. When the volume is clicked "Off" the whole unit is powered off.

### 11. Battery Charge Status/Battery Empty

#### i. Normal operating status

The full battery LED indicates the battery inside EZGO is fully charged and will last 6-8 hours.

When the low battery LED is displayed and flashes, it indicates the battery will last 15 minutes or less. EZGO will power off when the battery is exhausted. Recharge the battery for continued portable use.

Caution: When the low battery LED is flashing, please turn Power/Volume knob to "OFF" and recharge the battery as soon as you can, or you can plug in the external power supply immediately.

The Battery Empty LED indicates either a battery is not installed or if it is installed there may be a problem with it. If a battery is installed and the Battery Empty LED is illuminated check to make sure the connecting wires are secure and the battery is not damaged. If it is a replacement battery check to make sure it is qualified.

#### ii. Charging status

When connected to mains, EZGO will immediately enter charging status. After 5 minutes the remaining charging time can be estimated as follows:

- a. If 3 Battery Charge Status LEDs are flashing in turn, 6-8 hours are needed for the battery to be fully charged.
- b. If 2 Battery Charge Status LEDs (Full and Half battery LED) are flashing in turn, 15 minutes to 4 hours are needed for the battery to fully charged.
- c. If there is only one Battery Charge Status LED (Full) displayed and it is non-flashing, the battery is fully charged and EZGO can be normally used and operated.

### 12. External Power

When EZGO is connected to an external DC or AC power supply, the "External Power" LED illuminates.

## Battery



Battery is installed here.

Caution: Danger of explosion if battery is incorrectly replaced. Replace only with the same or equivalent type. Contact the service centre to ask for the help on this replacement.

### Handle

Extend the handle for portability. Retract when not in use. Do not use the extendable handle to lift EZGO.



### Power IN

#### 1. DC12V/6A jack

A DC jack can be used to connect to an external power supply. When the external power supply is connected the inner circuit for the battery will disconnect automatically and the battery will not be charged.

#### 2. AC socket

When connected to mains via the supplied power cord the unit is supplied with external power. The battery inside will also charge and the circuit for the DC power supply will automatically disconnect (EZGO will not draw power from the battery).

### Optional USB Module



#### 1. USB Input Level

The USB Input Level Knob controls the volume from USB Drive and USB to PC. When it is turned to "OFF", the whole USB module is powered off.



### 2. Remote control infrared receiver

This sensor receives signals from the accessory remote control. Do not place anything in front of the sensor.

### 3. Display

The display shows if there is a drive inserted in the USB Drive input, what files are on the drive, what operation the unit is performing, which track is playing, the lapse of time and the number of total tracks.

### 4. STOP

Press to stop playing or to go back to the upper level of folders.

### 5. PLAY/PAUSE

Press to play or pause while in track mode. Press to enter a selected folder when in folder mode.

### 6. Previous Track/Fast Reverse

Press to go to the previous track while playing or the previous track in the track list. Press and hold for fast reverse.

### 7. Next Track/Fast Forward

Press to go to the next track while playing or the next track in the track list. Press and hold for fast forward.

\*The USB Module buttons (Stop, Play/Pause, Fast Reverse/Previous Track, Fast Forward/Next Track) and the remote control are only functional when the unit is operating from the "USB Drive". When a device is connected to the "USB to PC", that device will control these operations.

### 8. USB Drive

Supports MP3/WMA file playback

### 9. USB to PC

The USB connector enables computers with USB connectivity to interface directly with EZGO for full duplex recording and playback. You may use a USB A Male to USB B Male cable to connect between a PC and EZGO.

In recent years the introduction of USB connectivity has ushered in a new appreciation of computer audio capabilities helping to fuse digital with analogue and opening up endless possibilities for recording musicians. The internal AD (Analogue to Digital) and DA (Digital to Analogue) converters are 16-bit/48KHz enabling recording and playback above CD quality. This ensures the recordings you make with a Wharfedale Pro Connect Mixer will have outstanding quality. EZGO is fully class compliant and requires no drivers when used with modern operating systems. Mac OSX, Windows XP, Vista and 7 require no additional driver software to function with EZGO.

### Remote Controller for USB Module

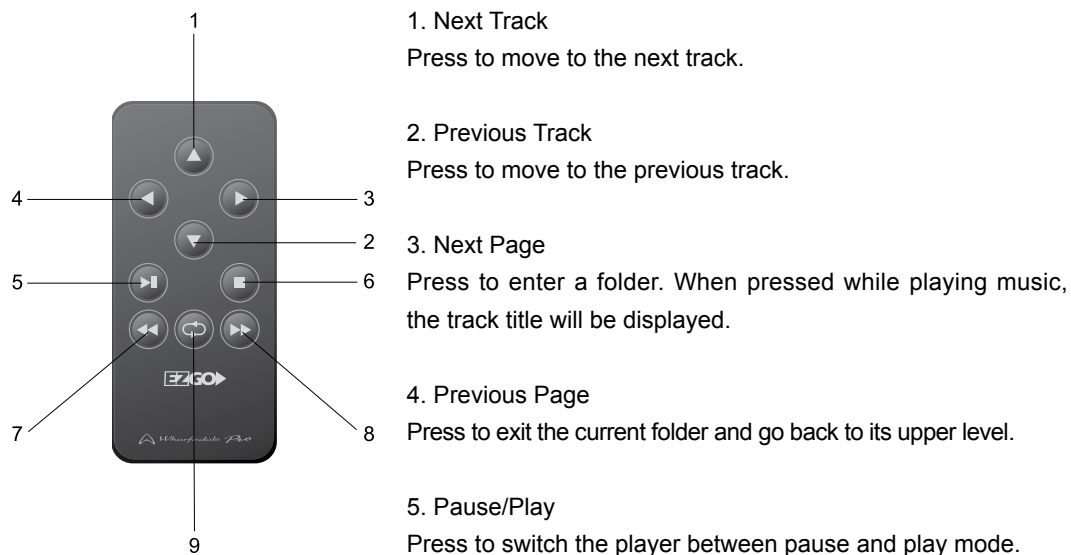

6. Stop  
Press to stop playing.

7. Fast Reverse  
Press and hold while playing to fast reverse.

8. Fast Forward  
Press and hold while playing to fast forward.

9. Repeat  
Press to switch the repeat mode between all track repeat setting (default setting) and one track repeat setting. "REPEAT" will be indicated on the LCD display when one track repeat setting is selected.

### Optional Wireless Microphone Receiver

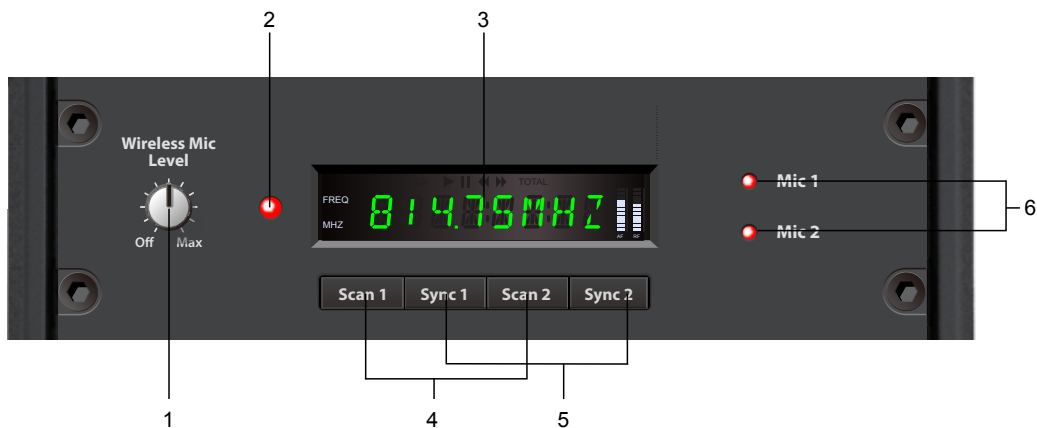

1. Mic Level  
The Mic Level knob controls the output level of the wireless Mic. When it is turned off, the Mic module is powered off.

**2. IR Emitter Window**

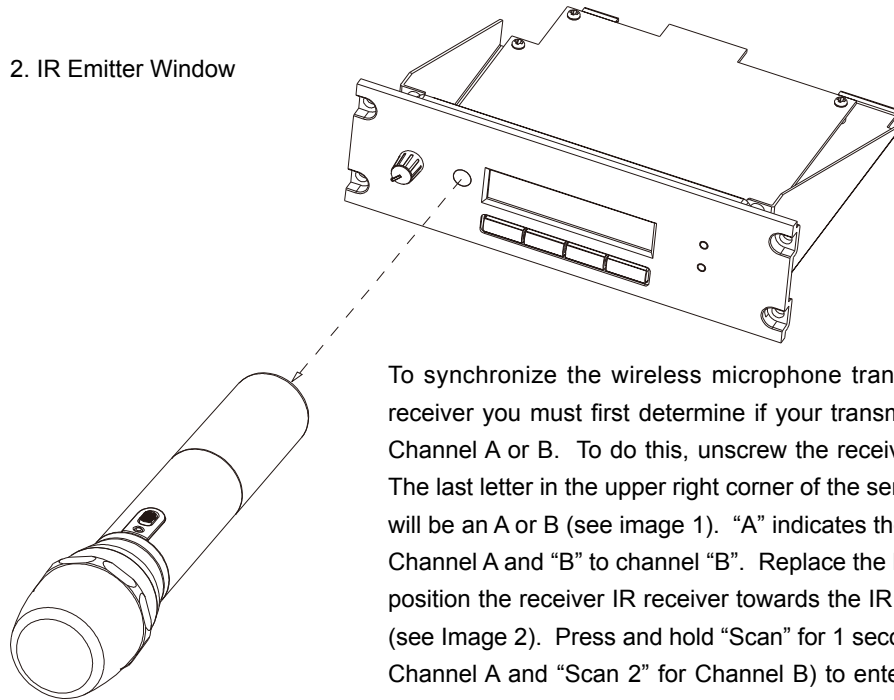

To synchronize the wireless microphone transmitter with the receiver you must first determine if your transmitter is tuned to Channel A or B. To do this, unscrew the receiver back handle. The last letter in the upper right corner of the serial number label will be an A or B (see image 1). "A" indicates the mic is tuned to Channel A and "B" to channel "B". Replace the back handle and position the receiver IR receiver towards the IR Emitter Window (see Image 2). Press and hold "Scan" for 1 second ("Scan 1" for Channel A and "Scan 2" for Channel B) to enter Search Mode. After the frequency stops scrolling press the "Sync" button ("Sync 1" for Channel A and "Sync 2" for Channel B). The RF signal strength on the right will indicate a full display showing the frequency synchronization has been done successfully.



**3. Display**

The display shows the wireless microphone transmitter's frequency and its signal strength with the connected module. AF level indicates the level of audio signal while RF indicates the signal strength.

**4. Scan 1 / Scan 2**

A & B channel search buttons. Press to enable the search function. The receiver will automatically search for a non-interference frequency at 1 MHz intervals and stop on the first one with a clear connection.

**5. Sync 1 / Sync 2**

A & B Channel synchronization buttons. Press "Sync 1" or "Sync 2" to synchronize the wireless microphone transmitter with the receiver.

**6. Channel Indicators**

A/B channel AF indicator. When "Mic 1" illuminates, the information of channel A is shown on the LCD display. When "Mic 2" illuminates, the information of channel B is shown on the LCD display.

Note: Occasionally transmitting devices like cellular telephones and handhold transceivers can cause interference to this product. If interference occurs move the source of interference away from EZGO.

### Changing Wireless Microphone Transmitter Batteries

The diagram below indicates how to change the wireless microphone transmitter batteries:

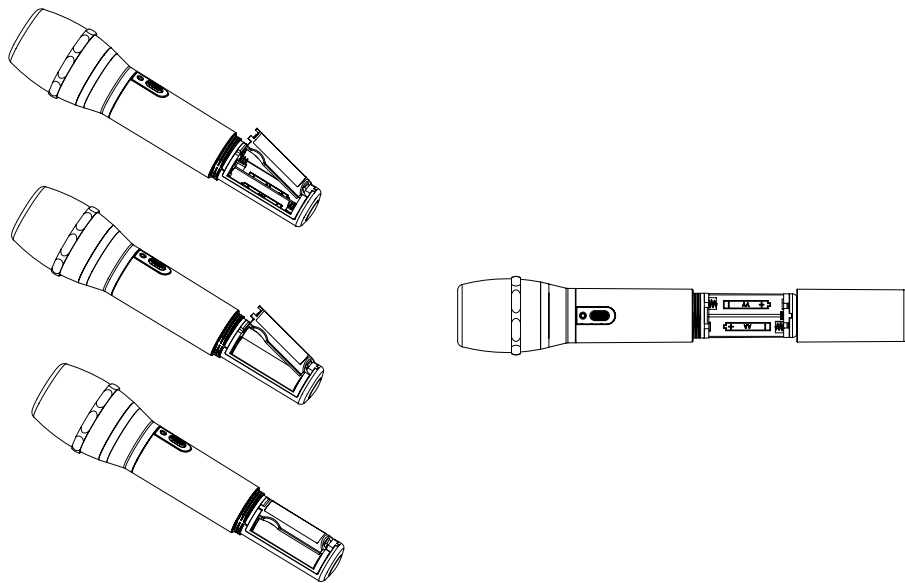

The right way to hold the wireless microphone transmitter is shown as below



- ▲ Note: A built-in aerial is located in the back handle of the wireless microphone transmitter. Holding the microphone by the back handle will decrease transmitting efficiency.

# FRONT PANEL LAYOUT

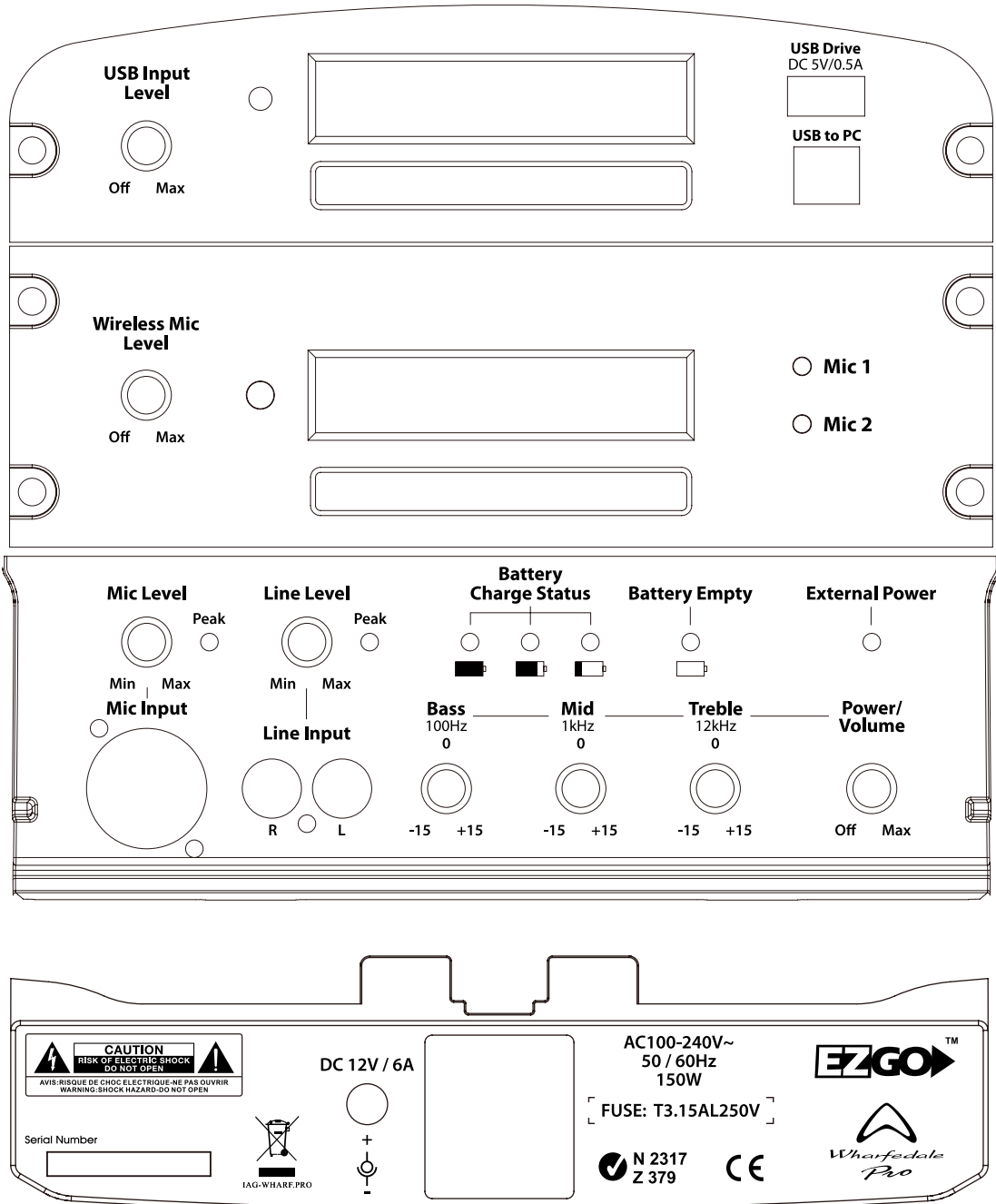

# DIMENSION DRAWING

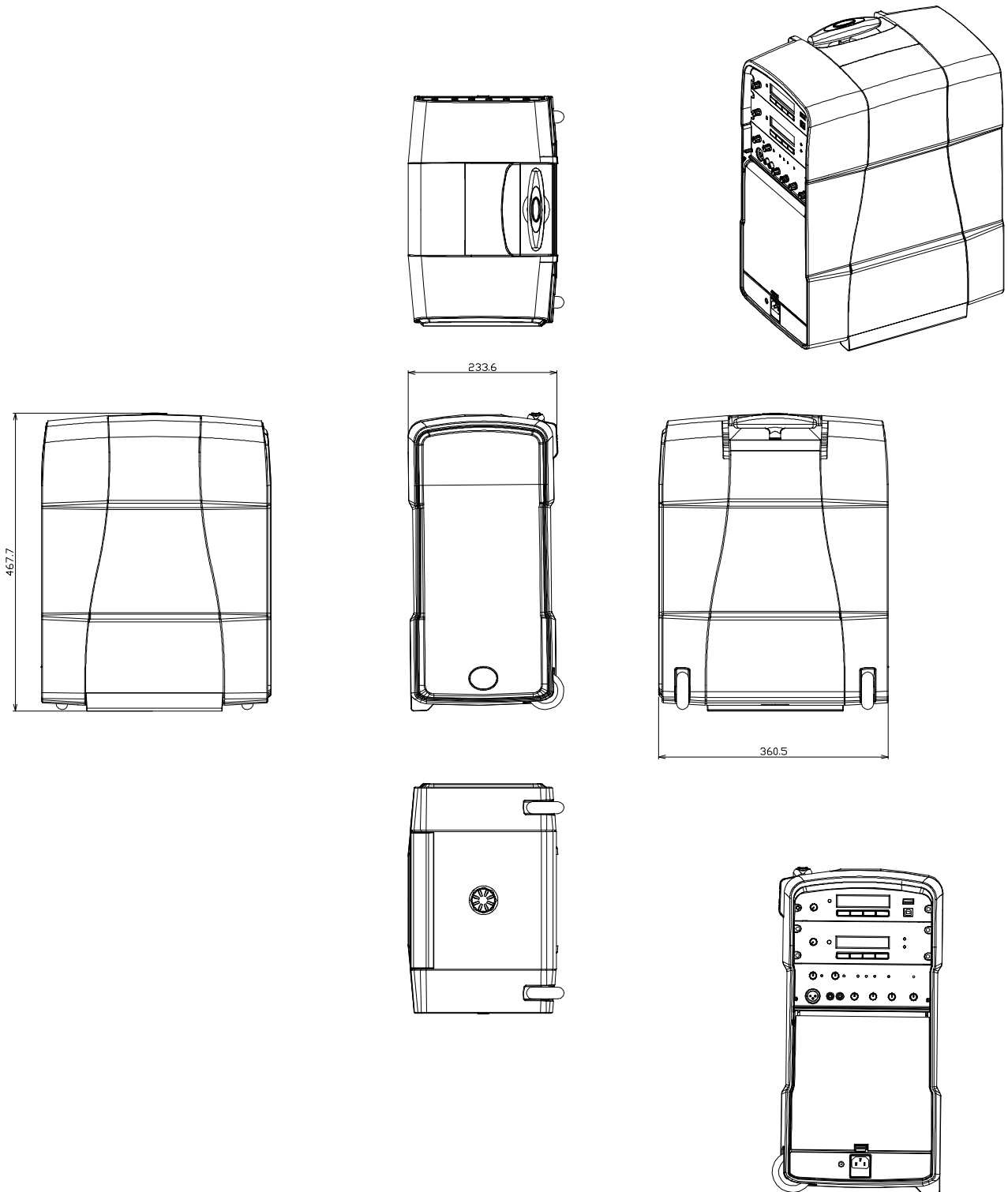

## SPECIFICATIONS

### Main Unit

Item	Specification
System Type	Full range
Frequency Response @ +/- 3dB	60-18kHz
Sensitivity 1w@1m/dB	98
Peak SPL (dB)	122
System Impedance $\Omega$	4
Driver Size (inch/mm)	5/125
Grille Material	Steel
Driver Impedance $\Omega$	8
Power Output	70W RMS, 140W Peak Power
THD	<0.1%
Signal-to-Noise Ratio	>80dB
Frequency Response	50Hz~18KHz $\pm$ 3dB
EQ	Bass, Mid, Treble $\pm$ 15dB
Power Supply	Battery, External DC, AC Power
Battery Life	Approx 8 hours for Full Battery Level
AC Power Supply	AC100~240V 50/60Hz
Protection	Short Circuit, Thermal Protect
Enclosure Type	Vented
Finish Colour	Black
Construction Material	ABS
Thickness	8 mm
Grille Color	Black
Rubber Feet	1
Mic in	XLR Female
Line in	RCA Jack
Input Sensitivity	Mic in: -44dBu Line in: -10dBu
Mic Level Control	Infinity to 65dB
Line level Control	Infinity to 40dB
Peak LED	MIC Peak LED on when input level > 8dB Line Peak LED on when input level > -38dB
Power/Volume Control	Master Volume Control with Off Infinity to 30dB
Battery Charge Status LEDs	Green for full Yellow for half Red for low Red for empty
Battery Empty warning LED	Green
Power Supply	DC Jack, 12V/6A IEC Jack, AC100~240V 50/60Hz
Dimension L x H x W (mm)	360 x 468 x 247
Net Weight	12.2kg
Gross Weight	14.0kg

### USB Module

Item	Specification
USB Level Input	Infinity to 40dB
Input Sensitivity	-10dBu
USB Drive	Support MP3 and WMA playback Supported Sampling Rate: 8KHz, 11.025KHz, 16KHz, 22.05KHz, 32KHz, 44.1KHz, 48KHz
USB to PC	Sound card for playback and recording on PC or Mac

### Wireless Microphone Transmitter

Item	Specification
Receiving Mode	Point to point receiving
Frequency Range	702-865 MHz
Bandwidth	24 MHz X 2
Channel Quantity	100 Channel X 2
Image Rejection Ratio	45dB normal, 50dB maximum
Signal-to-Noise Ratio	$\geq$ 95dB ( $\pm$ 40kHz frequency deviation, A-weighted)
Total Harmonic Distortion	$\leq$ 1% (1KHz, $\pm$ 40K frequency deviation)
Sensitivity	10dBuV (1KHz, $\pm$ 40K frequency deviation, S/N 65 dB)
Audio Output	5.4V (RMS, 1kHz signal, 40K Hz frequency deviation, 47K load)

### Wireless Microphone Receiver

Item	Specification
Frequency Range	702-865 MHz
Bandwidth	24 MHz
Oscillation	PLL Phase Locked
Frequency Stability	$\pm$ 0.005% 5 $^{\circ}$ C~+45 $^{\circ}$ C
Channel Separation	250 KHz
Channel Quantity	100 Channel
Tuning Type	FM tuning
Total Harmonic Distortion	$\leq$ 0.5% @1KHz
Transmitting Output Power	10 mW (in accordance with radio rules)
Harmonic Radiation	$\leq$ 55dBc
Maximum Modulation	$\pm$ 68 KHz
Batteries	AA battery X 2
Consuming Current	150mA (Approx)
Dimension	$\Phi$ 53mm X 220mm (Diameter X Height)
Weight	150g (Approx) (without batteries)

### Wireless Microphone Transmitter/ Receiver Integrated Parameters

Item	Specification
Bandwidth	UHF Band
Signal-to-Noise Ratio	$\geq$ 95dB (A-weighted)
Frequency Response	60 Hz to 12 KHz $\pm$ 3dB
Environmental Temperature	5 $^{\circ}$ C ~ 45 $^{\circ}$ C
Operating Distance	50m (open outdoor places)

## BEFORE YOU ASK FOR REPAIR SERVICES

While the unit is used, an unusual phenomenon may be confused as a malfunction for a certain reason. Prior to asking us for repair services, please check the table below and read the instruction manual for the subsidiary devices.

Refer to the trouble shooting list below if you experience difficulties operating EZGO. If you are unable to identify a solution please contact your authorized Wharfedale Pro dealer or distributor.

Problem	Cause/Solution
No Power	<ul style="list-style-type: none"> <li>- Connect the power cable to the AC inlet / DC Jack</li> <li>- If the power cable is not connected, make sure the battery has been charged</li> </ul>
No LCD display when the unit is on	<ul style="list-style-type: none"> <li>- Make sure that both the "USB Input Level" knob and "Wireless Mic Level" knobs are turned on.</li> </ul>
No Track when playing USB drive	<ul style="list-style-type: none"> <li>- Make sure the files inside the USB drive are in MP3 and WMA format</li> </ul>
The USB remote control cannot be operated	<ul style="list-style-type: none"> <li>- Make sure the remote control is within operating range</li> <li>- The battery is dead and the remote control needs to be replaced</li> </ul>
No audio from wireless module	<ul style="list-style-type: none"> <li>- Check that the transmitter and receiver are on the same channel</li> <li>- Make sure the wireless mic is within operating range</li> <li>- Check the power level of the microphone batteries.</li> </ul>
Interference and signal disturbances	<ul style="list-style-type: none"> <li>- When two transmitters are being used, select different frequencies. If voice disturbance still occurs, try selecting another channel until interference is gone.</li> <li>- Make sure there are no other wireless systems operating on the same frequencies in the area. This includes other wireless microphones, television or radio stations, etc. Try setting the transmitter and receiver to a new channel</li> </ul>



## APPENDIX I: FREQUENCY CODE LIST

EZ-GO WIRELESS FREQUENCY MATRIX (F1A)										
MIC1: 765-789(MHz)										
GROUP CHANNEL	1	2	3	4	5	6	7	8	9	10
1	765.000	767.500	770.000	772.500	775.000	777.500	780.000	782.500	785.000	787.500
2	765.250	767.750	770.250	772.750	775.250	777.750	780.250	782.750	785.250	787.750
3	765.500	768.000	770.500	773.000	775.500	778.000	780.500	783.000	785.500	788.000
4	765.750	768.250	770.750	773.250	775.750	778.250	780.750	783.250	785.750	788.250
5	766.000	768.500	771.000	773.500	776.000	778.500	781.000	783.500	786.000	788.500
6	766.250	768.750	771.250	773.750	776.250	778.750	781.250	783.750	786.250	788.750
7	766.500	769.000	771.500	774.000	776.500	779.000	781.500	784.000	786.500	789.000
8	766.750	769.250	771.750	774.250	776.750	779.250	781.750	784.250	786.750	789.250
9	767.000	769.500	772.000	774.500	777.000	779.500	782.000	784.500	787.000	789.500
10	767.250	769.750	772.250	774.750	777.250	779.750	782.250	784.750	787.250	789.750

EZ-GO WIRELESS FREQUENCY MATRIX (F1B)										
MIC2: 791-815(MHz)										
GROUP CHANNEL	1	2	3	4	5	6	7	8	9	10
1	791.000	793.500	796.000	798.500	801.000	803.500	806.000	808.500	811.000	813.500
2	791.250	793.750	796.250	798.750	801.250	803.750	806.250	808.750	811.250	813.750
3	791.500	794.000	796.500	799.000	801.500	804.000	806.500	809.000	811.500	814.000
4	791.750	794.250	796.750	799.250	801.750	804.250	806.750	809.250	811.750	814.250
5	792.000	794.500	797.000	799.500	802.000	804.500	807.000	809.500	812.000	814.500
6	792.250	794.750	797.250	799.750	802.250	804.750	807.250	809.750	812.250	814.750
7	792.500	795.000	797.500	800.000	802.500	805.000	807.500	810.000	812.500	815.000
8	792.750	795.250	797.750	800.250	802.750	805.250	807.750	810.250	812.750	815.250
9	793.000	795.500	798.000	800.500	803.000	805.500	808.000	810.500	813.000	815.500
10	793.250	795.750	798.250	800.750	803.250	805.750	808.250	810.750	813.250	815.750

EZ-GO WIRELESS FREQUENCY MATRIX			
MIC1:786-789MHz (F2A)		MIC2:823-826MHz (F2B)	
Channel	Frequency	Channel	Frequency
1	786.000 MHz	1	823.000 MHz
2	786.250 MHz	2	823.250 MHz
3	786.500 MHz	3	823.500 MHz
4	786.750 MHz	4	823.750 MHz
5	787.000 MHz	5	824.000 MHz
6	787.250 MHz	6	824.250 MHz
7	787.500 MHz	7	824.500 MHz
8	787.750 MHz	8	824.750 MHz
9	788.000 MHz	9	825.000 MHz
10	788.250 MHz	10	825.250 MHz
11	788.500 MHz	11	825.500 MHz
12	788.750 MHz	12	825.750 MHz
13	789.000 MHz	13	826.000 MHz

EZ-GO WIRELESS FREQUENCY MATRIX (F3A)										
MIC1: 816-840(MHz)										
GROUP CHANNEL	1	2	3	4	5	6	7	8	9	10
A	816.000	818.500	821.000	823.500	826.000	828.500	831.000	833.500	836.000	838.500
2	816.250	818.750	821.250	823.750	826.250	828.750	831.250	833.750	836.250	838.750
3	816.500	819.000	821.500	824.000	826.500	829.000	831.500	834.000	836.500	839.000
4	816.750	819.250	821.750	824.250	826.750	829.250	831.750	834.250	836.750	839.250
5	817.000	819.500	822.000	824.500	827.000	829.500	832.000	834.500	837.000	839.500
6	817.250	819.750	822.250	824.750	827.250	829.750	832.250	834.750	837.250	839.750
7	817.500	820.000	822.500	825.000	827.500	830.000	832.500	835.000	837.500	840.000
8	817.750	820.250	822.750	825.250	827.750	830.250	832.750	835.250	837.750	840.250
9	818.000	820.500	823.000	825.500	828.000	830.500	833.000	835.500	838.000	840.500
10	818.250	820.750	823.250	825.750	828.250	830.750	833.250	835.750	838.250	840.750

EZ-GO WIRELESS FREQUENCY MATRIX (F3B)										
MIC2: 841-865(MHz)										
GROUP CHANNEL	1	2	3	4	5	6	7	8	9	10
1	841.000	843.500	846.000	848.500	851.000	853.500	856.000	858.500	861.000	863.500
2	841.250	843.750	846.250	848.750	851.250	853.750	856.250	858.750	861.250	863.750
3	841.500	844.000	846.500	849.000	851.500	854.000	856.500	859.000	861.500	864.000
4	841.750	844.250	846.750	849.250	851.750	854.250	856.750	859.250	861.750	864.250
5	842.000	844.500	847.000	849.500	852.000	854.500	857.000	859.500	862.000	864.500
6	842.250	844.750	847.250	849.750	852.250	854.750	857.250	859.750	862.250	864.750
7	842.500	845.000	847.500	850.000	852.500	855.000	857.500	860.000	862.500	865.000
8	842.750	845.250	847.750	850.250	852.750	855.250	857.750	860.250	862.750	865.250
9	843.000	845.500	848.000	850.500	853.000	855.500	858.000	860.500	863.000	865.500
10	843.250	845.750	848.250	850.750	853.250	855.750	858.250	860.750	863.250	865.750

## APPENDIX II: ADDITIONAL USB SPECIFICATION

NO U Disk	Press any key(contain remote), show "NO DEV" 6sec then return
With U Disk but no MP3/WMA file	Press any key(contain remote), show"NO TRK" 6sec then return
The U Disk format is FAT	Support MP3, WMA file
The U Disk format is NTFS	This format is not supported
Maximum bytes supported for U Disk	32G
Maximum bytes supported for MP3/WMA single file	36.5M
Sampling rates supported	8KHz, 11.025KHz, 16KHz, 22.05KHz, 32KHz, 44.1KHz, 48KHz
Maximum number words supported for folder name	255 character
Maximum number words supported for file name	255 character MP3 file
Maximum number of sub_folders supported	6
Maximum number of folders in root_directory supported	200
Maximum number of files in a folder supported	2200

### WHARFEDALE PRO LIMITED WARRANTY

Wharfedale Pro products are warranted of manufacturing or material defects for a period of one year from the original date of purchase. In the event of malfunction, contact your authorized Wharfedale Pro dealer or distributor for information.

\* Be aware that warranty details may differ from country to country. Contact your dealers or distributor for information. These terms do not infringe your statutory rights.



Wharfedale Professional

IAG HOUSE, Sovereign Court, Ermine Business Park Huntingdon, Cambs, PE29 6XU, England

[www.wharfedalepro.com](http://www.wharfedalepro.com)

Wharfedale Professional reserves the right to alter or improve specifications without notice.  
All rights reserved © 2012 Wharfedale Pro. Wharfedale Pro is a member of the IAG Group.